



DESIGN FOR ALL 4CA



SANITARY | ACCESSORIES AND ACCESSIBILITY

MADE
IN ITALY

DESIGN.
FOR ALL
NORTH AMERICA

THE **DESIGN FOR ALL** BATHROOM ACCESSORIES PROGRAM DEMONSTRATES HOW ELEGANT, WELL-COORDINATED DESIGN CAN ELEVATE THE APPEARANCE AND PERFORMANCE OF ACCESSIBLE SPACES. SMARTLY DETAILED AND EXCEPTIONALLY WELL CRAFTED, EACH PRODUCT PROMOTES A LIFE WITHOUT BARRIERS AND SUPPORTS INCLUSION BEAUTIFULLY. PBA COLLABORATED WITH GENSLER, SERVING AS PRODUCT MERCHANDISING CONSULTANT, ON THE COMPLETE RANGE, WHICH IS SUITABLE FOR OFFICE, HOSPITALITY, RETAIL, HEALTHCARE. AND EDUCATION ENVIRONEMENTS.

DESIGN FOR ALL
4CA

ALUMINUM





**PBA
ANTI-MICROBIAL COATING**

AMC

PRODUCTS IN ALUMINUM HAVE NATURAL ANTIBACTERIAL PROPERTIES AND A GOOD HANDLE ON CLEANLINESS. PBA ANTI-MICROBIAL COATING (AMC) IS AN INNOVATIVE FINISHING HIGHLY RECOMMENDED FOR ALL SITUATIONS WHERE HYGIENE IS EXTREMELY IMPORTANT NOT ONLY FOR THE DESTINATION, BUT ALSO FOR THE HIGH ATTENDANCE LIKE HOSPITALS AND GENERALLY PUBLIC SPACES.

AMC IS AVAILABLE FOR ALL THE ALUMINUM BATHROOM ACCESSORIES ON REQUEST.

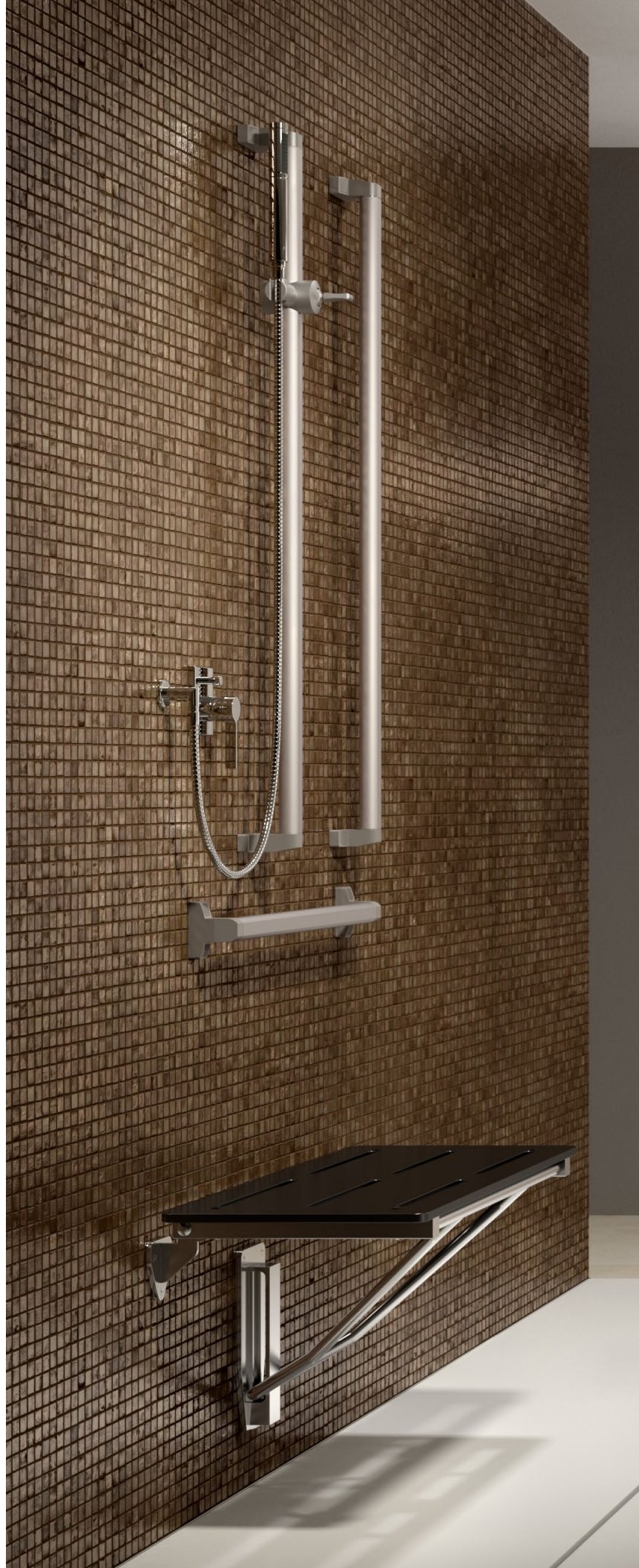

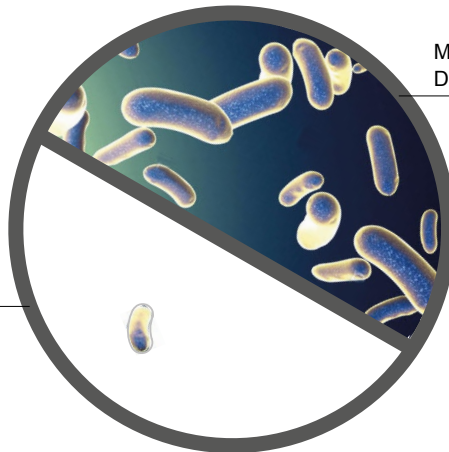

MULTI-RESISTANT PATHOGENS
DEVELOP WITHOUT PBA AMC

PBA AMC REDUCES PATHOGENS
BY ABOUT 99.99%

TRIED AND TESTED EFFICACY

REDUCES MULTI-RESISTANT PATHOGENS BY 99.99%.
(EFFECT OF ANTI-BACTERIAL ACTIVITY ON ALUMINUM SURFACES).

PBA ANTI-MICROBIAL COATING



THE **PBA ANTI-MICROBIAL COATING (AMC)** SURFACE FINISHING CONTAINS SPECIAL ADDITIVES THAT MAKE THE SURFACE PROTECTED FROM BACTERIA AND MICROORGANISMS. THE TESTS SHOW THAT ON UNTREATED SURFACES THE MICROBES AND BACTERIA CAN EASILY PROLIFERATE WHILE ON THE TREATED SURFACES THE BACTERIAL PROLIFERATION IS PRACTICALLY ZEROED.

TEST AND EFFICACY

THE FOUNDATION FOR SUCCESSFULLY FIGHTING GERM GROWTH CONSISTS OF A THREE ACTION MECHANISMS: BLOCKAGE OF PRIMARY CELL METABOLISM, STOPPAGE OF CELLULAR RESPIRATION, PREVENTION OF CELL DIVISION.

SURFACES WITH **PBA ANTI-MICROBIAL COATING (AMC)** HAVE BEEN TESTED TO BE ACTIVE AGAINST GRAM-POSITIVE (STAPHYLOCOCCUS AUREUS - MRSA, BACILLUS SUBTILIS, STREPTOCOCCUS DAECALIS, AND OTHERS) AND GRAM-NEGATIVE BACTERIA (ESCHERICHIA COLI - ESBL, LEGIONELLA PNEUMOPHILA, PSEUDOMONAS AERUGINOSA AND OTHERS).

WHERE TO USE

WE RECOMMEND **PBA ANTI-MICROBIAL COATING (AMC)** FOR ALL THE HYGENE-SENSITIVE AREAS SUCH AS HOSPITALS AND RETIREMENT HOME AND GENERALLY FOR PUBLIC BUILDINGS AND HOTELS.

CARE AND MAINTENANCE

PBA ANTI-MICROBIAL COATING (AMC) NEEDS THE SAME CARE OF STANDARD POWDER-COATED SURFACES. SEE PBA CATALOGUE TECHNICAL SECTION FOR MORE INFORMATION.

AMC FINISH

ALUMINUM POWDER COATED

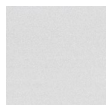

TRANSPARENT
SILVER

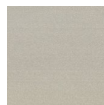

TRANSPARENT
LIGHT BRONZE

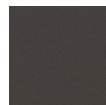

TRANSPARENT
DARK BRONZE



TRANSPARENT
BLACK

DESIGN FOR ALL 4CA

THE **DESIGN FOR ALL 4CA** ALUMINUM BATHROOM ACCESSORIES AND AIDS PROGRAM PROVES HOW ELEGANT, WELL-COORDINATED DESIGN CAN ELEVATE THE APPEARANCE AND PERFORMANCE OF ACCESSIBLE SPACES. SMARTLY DETAILED, EXCEPTIONALLY WELL CRAFTED, AND TO BE USED IN OFFICES, HOSPITALITY, RETAIL, HEALTHCARE AND EDUCATION, EACH PRODUCT WAS CREATED TO BEAUTIFULLY SUPPORT INCLUSION. THE ALUMINUM RANGE IS OFFERED IN A MODERN AND ELEGANT PALET OF COLORS.

ADA



PRODUCTS IN THIS COLLECTION WERE DESIGNED TO COMPLY WITH THE ADA AND SIMILAR ACCESSIBILITY REQUIREMENTS, HOWEVER FINAL INTERPRETATION OF ACCESSIBILITY COMPLIANCE IS THE RESPONSIBILITY OF THE SPECIFIER AND SHOULD BE DETERMINED ACCORDING TO SPECIFIC PROJECT CONDITIONS AND LOCAL CODES.

CERTIFICATE

CYTOTOXICITY TEST



Cytotoxicity test to DIN EN ISO 10993-5



EPD ENVIRONMENTAL PRODUCT DECLARATION

OUR CONTRIBUTION TO THE PROTECTION OF THE ECOSYSTEM

AN EPD IS AN ISO ENVIRONMENTAL DECLARATION BASED ON ISO 14025 AND ISO 21930 STANDARDS, TRANSPARENTLY REPORTING THE ENVIRONMENTAL PERFORMANCE OF PRODUCTS OR SERVICES FROM A LIFECYCLE PERSPECTIVE. THE PREPARATION OF AN EPD ENCOMPASSES VARIOUS STAGES, FROM ACQUIRING RAW MATERIALS TO THE END OF THE PRODUCT'S LIFE. EPDS ADHERE TO INTERNATIONAL STANDARDS AND CONSIDER THE ENTIRE VALUE CHAIN. ADDITIONALLY, THE EPD IS A THIRD-PARTY VERIFIED DOCUMENT. WE ARE PROUD TO OFFER THE EPD FOR OUR PRODUCTS, AVAILABLE IN THE EPD LIBRARY.







pba FOR LEED® CERTIFICATION

OUR CONTRIBUTION TO THE EFFICIENCY AND SUSTAINABILITY OF BUILDINGS

LEED® (LEADERSHIP IN ENERGY ENVIRONMENTAL DESIGN) IS A VOLUNTARY CERTIFICATION SYSTEM FOR THE MANAGEMENT, DESIGN AND CONSTRUCTION OF BUILDINGS THAT ARE SUSTAINABLE FROM A SOCIAL, ENVIRONMENTAL AND ECONOMIC POINT OF VIEW AND IN TERMS OF THE WELLBEING OF THE USERS.

pba PRODUCTS CONTRIBUTE TOWARD SATISFYING PREREQUISITES AND CREDITS UNDER LEED®.

INTEGRATED PROCESS	IP	
MATERIALS AND RESOURCES	MR	
INDOOR ENVIRONMENTAL QUALITY	EQ	
INNOVATION	IN	



PBA LINES - CONTRIBUTION MATRIX TO LEED V4

CHART OF PBA PRODUCTS CONTRIBUTION TO LEED V4

INTEGRATIVE PROCESS 

IP PREREQUISITE INTEGRATIVE PROCESS PLANNING AND DESIGN

MATERIALS AND RESOURCES 

MR PREREQUISITE CONSTRUCTION AND DEMOLITION WASTE MANAGEMENT PLANNING

MR CREDIT CONSTRUCTION AND DEMOLITION WASTE MANAGEMENT

MR CREDIT BUILDING PRODUCT DISCLOSURE AND OPTIMIZATION - SOURCING OF RAW MATERIALS
➔ OPTION 2 LEADERSHIP EXTRACTION PRACTICES

MR CREDIT BUILDING PRODUCT DISCLOSURE AND OPTIMIZATION - MATERIAL INGREDIENTS
➔ OPTION 2 MATERIAL INGREDIENT OPTIMIZATION

INDOOR ENVIRONMENTAL QUALITY 

EQ CREDIT LOW EMITTING MATERIALS

EQ CREDIT CONSTRUCTION AIR QUALITY MANAGEMENT PLAN

INNOVATION 

IN PILOT CREDIT  DESIGN FOR FLEXIBILITY

IN PILOT CREDIT  SOCIAL EQUITY

IN PILOT CREDIT  INCLUSIVE DESIGN

IN CREDIT  DESIGN FOR DECONSTRUCTION

MATERIALS

ALUMINUM ALLOY EN-AW 6060

THE ALUMINUM 6060 ALLOY HAS AN EXCELLENT RESISTANCE TO CORROSION, TO LOW TEMPERATURES AND ALLOWS QUALITY WELDINGS. IN THE DESIGN WORLD IT IS COMMONLY USED TO CREATE COMPONENTS WITH COMPLEX SHAPES ALLOWING EXCELLENT QUALITY RESULTS COMPARED TO OTHER ALLOYS FOR ANODIZING TREATMENTS.

HIGH-STRENGTH ALUMINUM

IN ACCORDANCE WITH THE REGULATION UNI 9006, THE ALUMINUM USED IS CLASSIFIED AS ALUMINUM 6060. ITS COMPOSITION CONSISTS OF:

SILICIUM 0.4%	IRON 0.2%	MAGNESIUM 0.5%	ALUMINUM 98.9%
------------------	--------------	-------------------	-------------------

ITS MOST IMPORTANT MECHANICAL AND PHYSICAL PROPERTIES ARE:

UNIT LOAD OF THE TENSILE STRENGTH R _m (N/mm ²)	UNIT LOAD PROPORTIONAL ELASTIC LIMIT R _{p0.2} (N/mm ²)	DISTENSION A %	BRINELL HARDNESS HB	MODULE OF ELASTICITY E (N/mm ²)
205	165	10	80	66000

ALUMINUM UNDERGOES A CALORIFIC HARDENING TREATMENT AND IS AFTERWARD AGED ARTIFICIALLY BY HEATING FROM 170 °C TO 185 °C FOR A PERIOD OF 6 + 10 HOURS.

MAINTENANCE

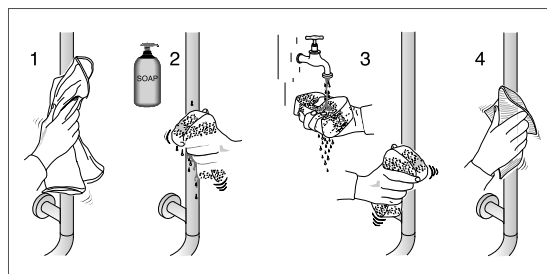
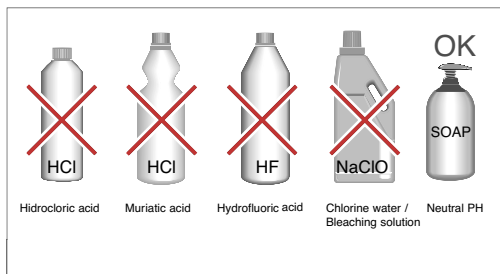

ONLY CLEAN WITH NEUTRAL PH SOAP

FINISH

RAIL
Anodized Aluminum

SUPPORTS AND BENDS
Powder Coated Aluminum Alloy and Zamak

SNAP OVER CAPS
Polyamide 6

.78
SILVER

AMC

AMC .99
TRANSPARENT
SILVER

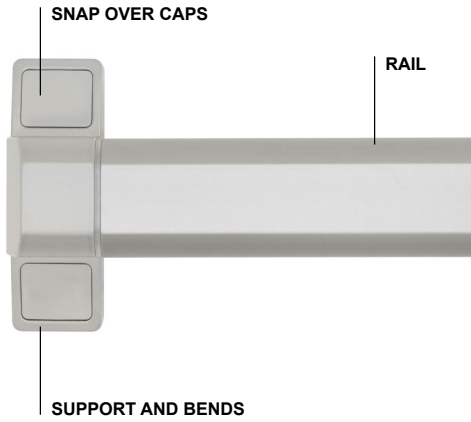

ACCESSORIES
Polyamide 6

.78
SILVER

RAIL
Anodized Aluminum

SUPPORTS AND BENDS
Powder Coated Aluminum Alloy and Zamak

SNAP OVER CAPS
Polyamide 6

.70
LIGHT
BRONZE

AMC

AMC .99
TRANSPARENT
LIGHT BRONZE

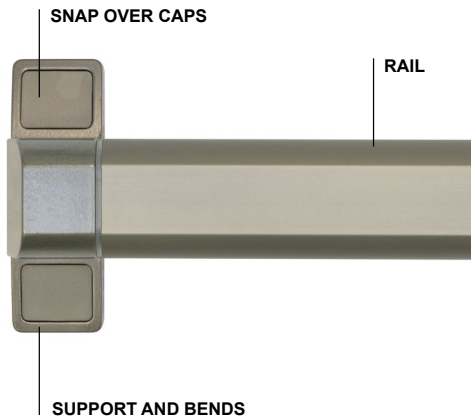

ACCESSORIES
Polyamide 6

.70
LIGHT
BRONZE

RAIL
Anodized Aluminum

SUPPORTS AND BENDS
Powder Coated Aluminum Alloy and Zamak

SNAP OVER CAPS
Polyamide 6

.79
DARK
BRONZE

AMC

AMC .99
TRANSPARENT
DARK BRONZE

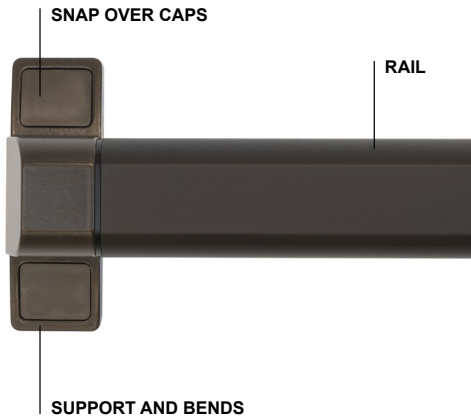

ACCESSORIES
Polyamide 6

.17
ANTHRACITE

RAIL
Anodized Aluminum

SUPPORTS AND BENDS
Powder Coated Aluminum Alloy and Zamak

SNAP OVER CAPS
Polyamide 6

.73
BLACK

AMC

AMC .99
TRANSPARENT
BLACK

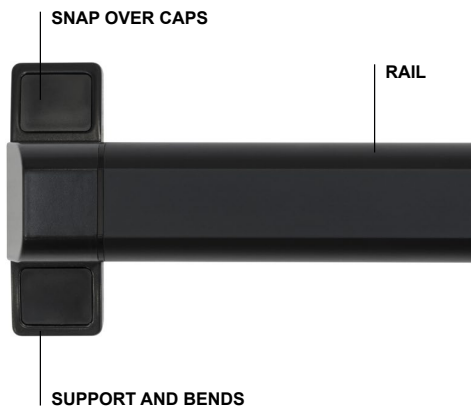

ACCESSORIES
Polyamide 6

.10
BLACK

STRUCTURAL ELEMENTS SAFETY BARS & EQUIPMENT



ALUMINUM AND POLYAMID-6 ARE COMPLETELY SEPARABLE FOR RECYCLE.

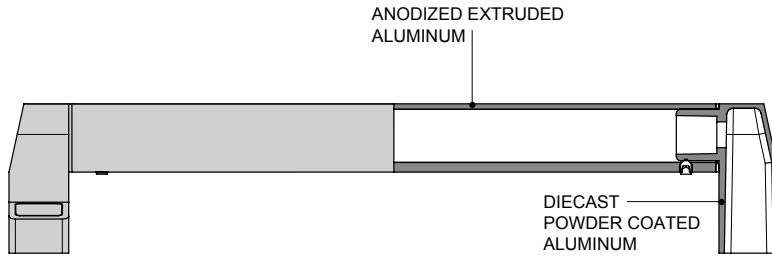

RAIL
EXTRUDED ALLOY EN AW-6060 ALUMINUM TUBE ANODIZED (HB=80MIN)

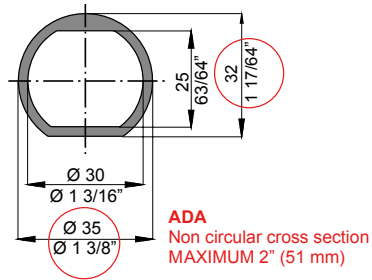

BEND 90°
DIE-CAST ALUMINUM BEND WITH CATHAPHORESIS TREATMENT AND POWDER COATING

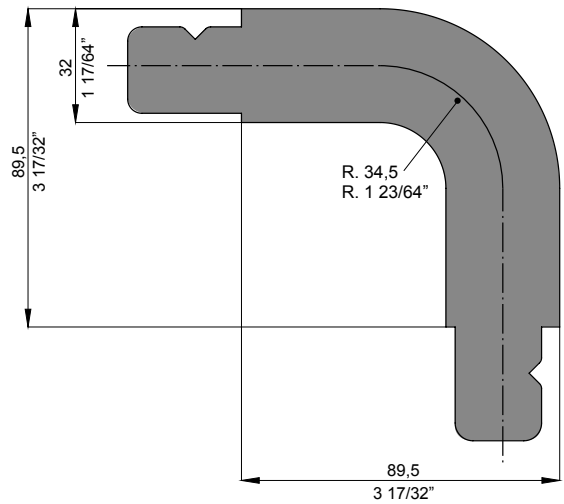

WALL SUPPORT
ZINC ALLOY SUPPORT (ZAMAK) WITH CATHAPHORESIS TREATMENT AND POWDER COATING

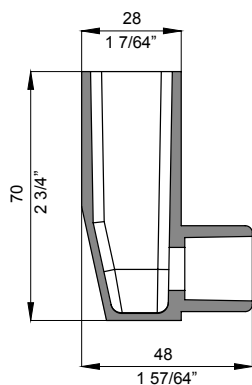

STRAIGHT SUPPORT
ZINC ALLOY SUPPORT (ZAMAK) WITH CATHAPHORESIS TREATMENT AND POWDER COATING

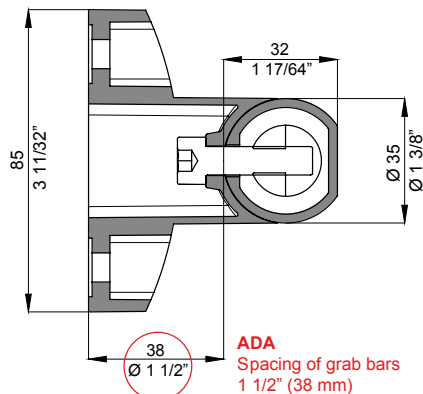

GRAB BARS	PAGE 135
SHOWER SEATS	PAGE 141
SHOWER ACCESSORIES	PAGE 145
WASHROOM ACCESSORIES	PAGE 153
TOILET ACCESSORIES	PAGE 157
SPECIAL ACCESSORIES	PAGE 161
TECHNICAL INFORMATION	PAGE 171

ITEM Items code ♦ Side: .1 Right  ADA
 Ø Diameter .2 Left
 α Angle

CODE'S STRUCTURE

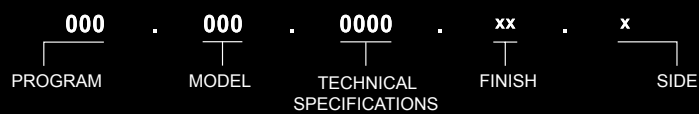

GRAB BARS

SHOWER SEATS



90° GRAB BARS

page 136



FOLDING SHOWER SEAT

page 142



HORIZONTAL GRAB BARS

page 138



FOLDING SHOWER SEAT

page 143



SWING UP GRAB BARS

page 139

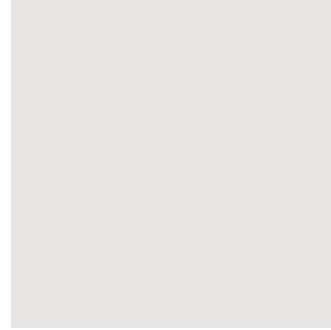
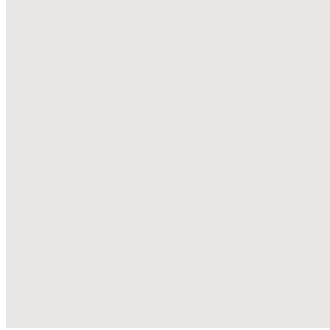
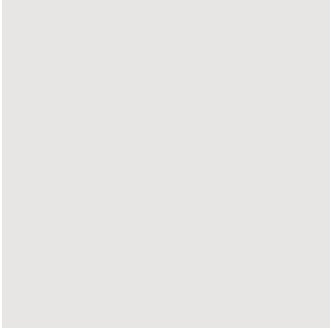
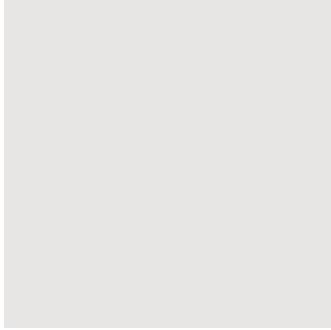
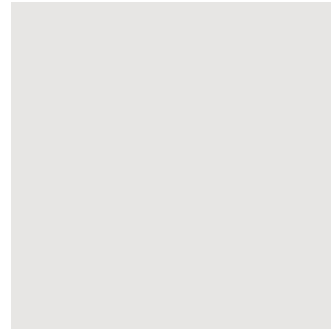
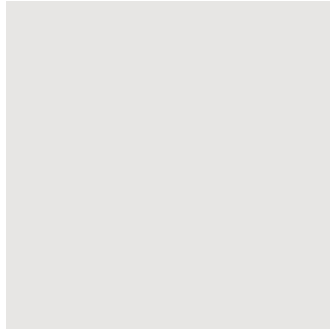
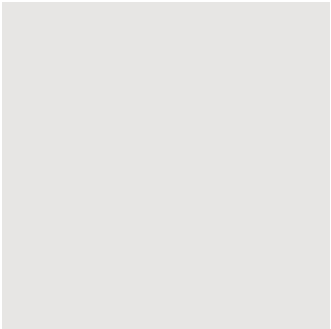
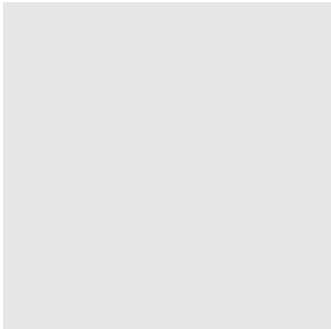

**SHOWER
ACCESSORIES**

**WASHROOM
ACCESSORIES**



SHOWER CURTAIN RAILS

page 146



FIXED MIRROR WITH
HOLDERS

ADJUSTABLE MIRROR

page 154



VERTICAL SHOWER HEAD
HOLDER RAIL

page 151

**TOILET
ACCESSORIES**

**SPECIAL
ACCESSORIES**



TOILET ROLL HOLDER

page 158



SHELVES

page 162



TOILET BRUSH SETS

page 159



CLOTH HOOKS

page 164

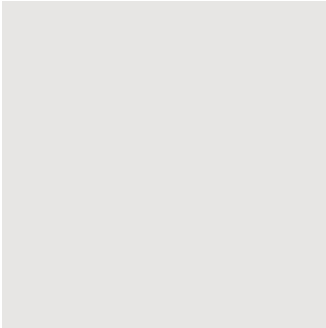
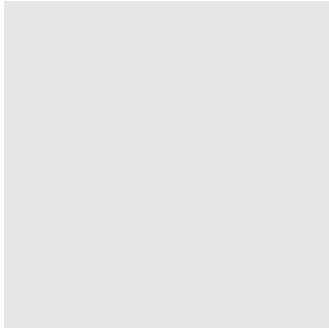

DOOR-STOP CLOTH HOOK

page 166

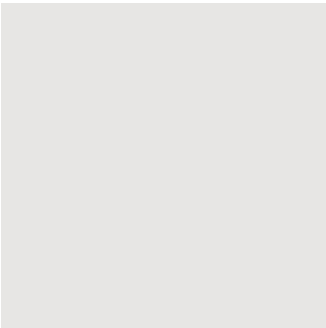
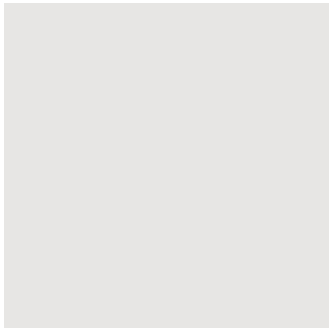

PICTOGRAMS

page 167

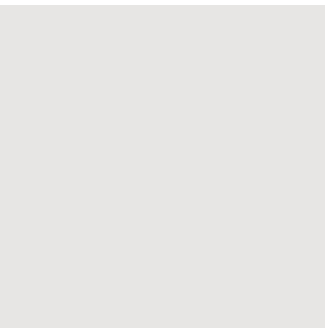
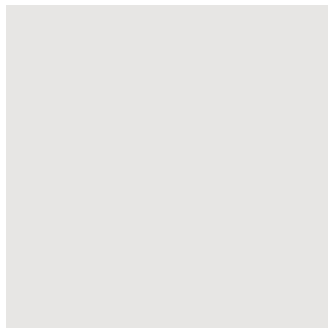
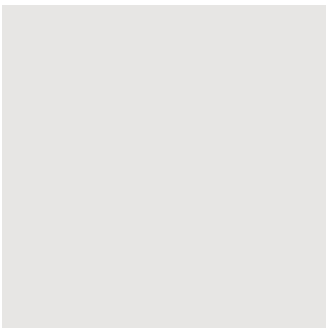
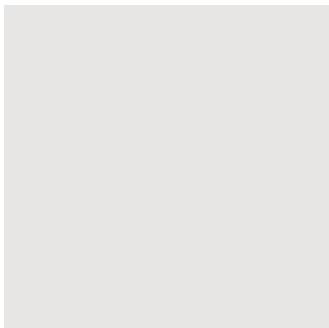



GRAB BARS



PBA
PATENTED
DESIGN

PATENT
IT0000101043

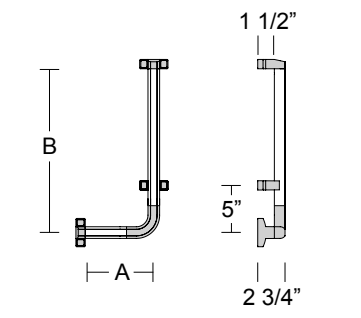

- Anodized aluminum
- Powder coated aluminum alloy

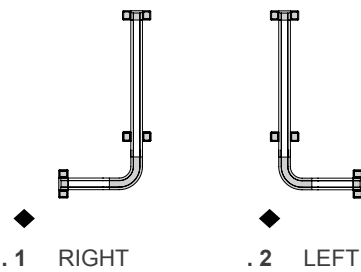

ITEM	◆	A	B
4CA.422.001U .xx . x		18"	24"
4CA.422.002U .xx . x		18"	36"
4CA.422.003U .xx . x		24"	24"
4CA.422.004U .xx . x		24"	36"
4CA.422.005U .xx . x		30"	24"
4CA.422.006U .xx . x		30"	30"
4CA.422.007U .xx . x		30"	36"



90° GRAB BAR

Rail 3/32" (2,5 mm) thick EN AW-6060 aluminum extruded and anodized with 1-3/8" (Ø35 mm) outer diameter. Die-cast aluminum bends with cathoresis pre-treatment and powder-coated finishing.

Wall support 3-11/32" x 1-7/64" (85 x 28 mm) in zinc alloy with cathoresis pre-treatment and powder-coated finishing. Fully recyclable polyamide-6 caps which snap over fixing holes to conceal mounting screws.

Clearance between the grab bar and wall is 1-1/2" (38 mm).
For installation see page 172. For maintenance see page 128.

MOUNTING KITS not included.

Optional mounting kit for concrete, natural stone, solid brick and hollow brick: KIT 4CN.0VM.0030.00.

Optional mounting kit for sheetrock wall and wooden plate: KIT 4CN.0VM.0032.00.

Optional mounting kit for toilet partition: KIT 4CN.0VM.0041.00.

One mounting kit is required for each wall support - see page 172.

SAFETY WARNING

Grab bars must be firmly secured to the anchors and the walls in order for them to support the weight they are designed for. Grab bars alone are not stronger than anchors and walls. In case the grab bar is not securely anchored to the wall, the building owner or maintenance personnel must remove it from service to avoid any accident or injury.

See Technical Data Sheet for load capacity

ALUMINUM				ANODIZED ALUMINUM TRANSPARENT POWDER COATED				A M C
.XX FINISH	.78	.70	.79	.73	.99	.99	.99	

This product contributes to LEED® credits



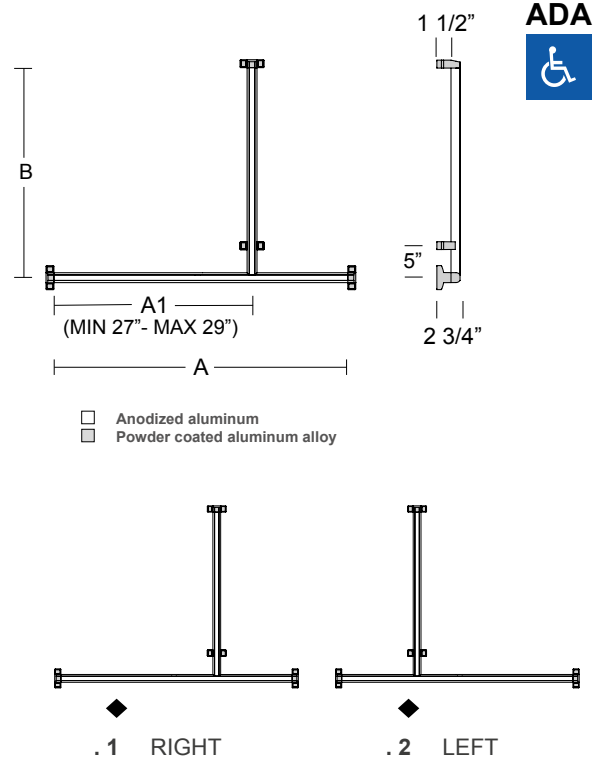

ITEM	◆	A	B
4CA.433.001U . xx . x		42"	24"
4CA.433.002U . xx . x		42"	36"



“T” SHAPED GRAB BAR

Rail 3/32" (2,5 mm) thick in EN AW-6060 aluminum extruded and anodized with 1-3/8" (Ø35 mm) outer diameter.
 Wall support 3-11/32 x 1-7/64" (85 x 28 mm) rectangular base in zinc alloy with cataphoresis pre-treatment and powder-coated finishing.
 Fully recyclable polyamide-6 caps which snap over fixing holes to conceal mounting screws.
 Clearance between the grab bar and wall is 1-1/2" (38 mm).
 For installation see page 172. For maintenance see page 128.

MOUNTING KITS not included.

Optional mounting kit for concrete, natural stone, solid brick and hollow brick: KIT 4CN.0VM.0030.00.
 Optional mounting kit for sheetrock wall and wooden plate: KIT 4CN.0VM.0032.00.
 Optional mounting kit for toilet partition: KIT 4CN.0VM.0041.00.
 One mounting kit is required for each wall support - see page 172.

SAFETY WARNING

Grab bars must be firmly secured to the anchors and the walls in order for them to support the weight they are designed for. Grab bars alone are not stronger than anchors and walls. In case the grab bar is not securely anchored to the wall, the building owner or maintenance personnel must remove it from service to avoid any accident or injury.

See Technical Data Sheet for load capacity

ALUMINUM					ANODIZED ALUMINUM TRANSPARENT POWDER COATED			
.XX FINISH	.78	.70	.79	.73	.99	.99	.99	.99

AMC

This product contributes to LEED® credits





PBA
PATENTED
DESIGN

PATENT
IT0000101043



PATENTED

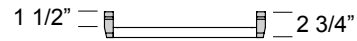
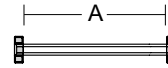

- Anodized aluminum
- Powder coated aluminum alloy

ITEM	A
4CA.440.001U .xx	12"
4CA.440.002U .xx	16"
4CA.440.003U .xx	18"
4CA.440.004U .xx	24"
4CA.440.005U .xx	30"
4CA.440.006U .xx	32"
4CA.440.007U .xx	36"
4CA.440.008U .xx	42"
4CA.440.009U .xx	48"



HORIZONTAL GRAB BAR

Rail 3/32" (2,5 mm) thick in EN AW-6060 aluminum extruded and anodized with 1-3/8" (Ø35 mm) outer diameter. Wall support 3-11/32 x 1-7/64" (85 x 28 mm) rectangular base in zinc alloy with cathoporesis pre-treatment and powder-coated finishing. Fully recyclable polyamide-6 caps which snap over fixing holes to conceal mounting screws. Clearance between the grab bar and wall is 1-1/2" (38 mm). For installation see page 172. For maintenance see page 128.

MOUNTING KITS not included.

Optional mounting kit for concrete, natural stone, solid brick and hollow brick: KIT 4CN.0VM.0030.00.
 Optional mounting kit for sheetrock wall and wooden plate: KIT 4CN.0VM.0032.00.
 Optional mounting kit for toilet partition: KIT 4CN.0VM.0041.00.
 One mounting kit is required for each wall support - see page 172.

SAFETY WARNING

Grab bars must be firmly secured to the anchors and the walls in order for them to support the weight they are designed for. Grab bars alone are not stronger than anchors and walls. In case the grab bar is not securely anchored to the wall, the building owner or maintenance personnel must remove it from service to avoid any accident or injury.

See Technical Data Sheet for load capacity

ALUMINUM				ANODIZED ALUMINUM TRANSPARENT POWDER COATED				A M C
.XX FINISH	.78	.70	.79	.73	.99	.99	.99	

This product contributes to LEED® credits



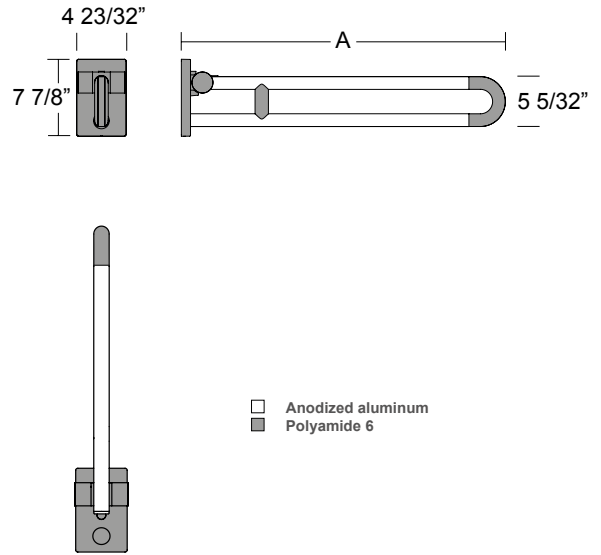

ITEM	A
4CA.445.001U .xx	29"
4CA.445.002U .xx	32"
4CA.445.003U .xx	34"

SWING UP GRAB BAR

Rail 15/64" (6 mm) thick extruded alloy EN AW-6060 aluminum tube anodized with 1-7/16" (36 mm) outer diameter. Fully recyclable polyamide-6 180° bend connected with tubes.

Backplate in diecast aluminum with fully recyclable polyamide-6 cover and wall protection. 3 screw holes for attachment to wall.

Spring Load Rotation system with adjustable friction in fully recyclable polyamide-6 and diecast aluminum inner core.

For installation see page 173. For maintenance see page 128.

MOUNTING KITS not included.

Optional mounting kit for concrete, natural stone, solid brick and hollow brick: KIT 4CN.0VM.0014.00.

Optional mounting kit for sheetrock wall and wooden plate: KIT 4CN.0VM.0017.00.

SAFETY WARNING

Grab bars must be firmly secured to the anchors and the walls in order for them to support the weight they are designed for. Grab bars alone are not stronger than anchors and walls. In case the grab bar is not securely anchored to the wall, the building owner or maintenance personnel must remove it from service to avoid any accident or injury.

See Technical Data Sheet for load capacity

This product contributes to LEED® credits

ALUMINUM

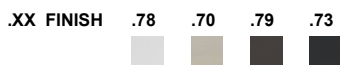

ANODIZED ALUMINUM TRANSPARENT POWDER COATED

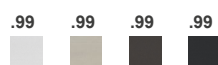

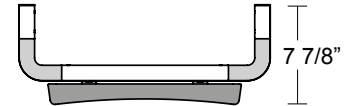
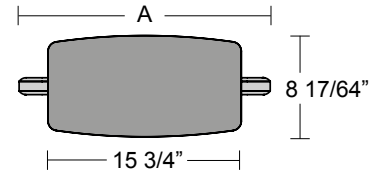

- Anodized aluminum
- Powder coated aluminum alloy
- Polyurethane

ITEM	A
4CA.434.0000 .xx	19 19/64"
4CA.434.000L .xx	27 9/16"

ALUMINUM BACKREST

Rail 3/32" (2,5 mm) thick EN AW-6060 aluminum extruded and anodized with 1-3/8" (Ø35 mm) outer diameter. Die-cast aluminum bends with cathoresis pre-treatment and powder-coated finishing.
 Backrest in black foamed polyurethane.
 Mounting kit for solid brick / concrete included.
 For maintenance see page 128.

MOUNTING KITS included.

ALUMINUM

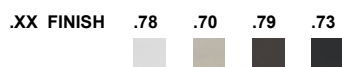

ANODIZED ALUMINUM TRANSPARENT POWDER COATED

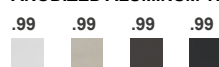

This product contributes to LEED® credits



SHOWER SEATS

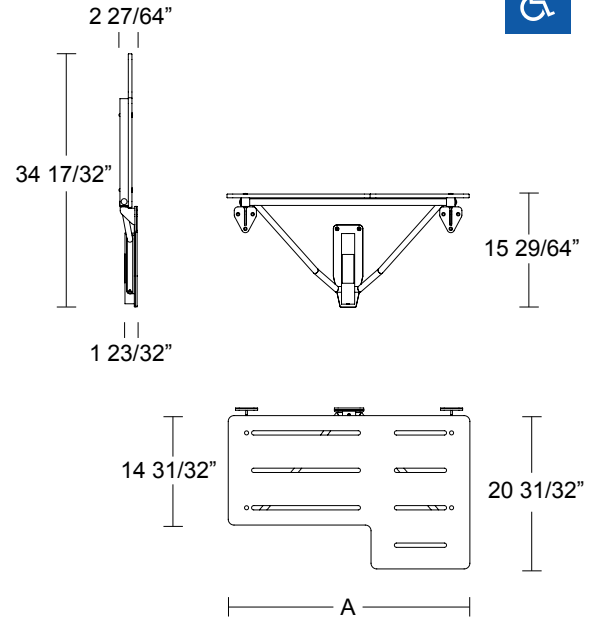

ITEM	A
4CS.447.UL01 . xx	21"
4CS.447.UL02 . xx	27"
4CS.447.UL03 . xx	33"

FOLDING SHOWER SEAT

Seat 1/2" (13 mm) thick solid high pressure laminated (HPL) with slots for water drainage, connected to frame with type-316 stainless steel bolts. Reversible for left / right installation on site.

Frame type-316L satin finish stainless steel 1-1/4" (30 mm) square tube connected with 25/32" (20 mm) diameter tube.

Mounting flanges and Guide Bracket in type-316L satin finish stainless steel 15/64" (6 mm) thick with fully recyclable polyamide-6 wall protection. 9 screw holes for attachment to wall.

Adjustable frictioning system.

For installation see page 174.

MOUNTING KITS not included.

Optional mounting kit for concrete, natural stone, solid brick and hollow brick: KIT 4CN.0VM.0042.00.

Optional mounting kit for sheetrock wall and wooden plate: KIT 4CN.0VM.0043.00.

See Technical Data Sheet for load capacity

This product contributes to LEED® credits

STAINLESS STEEL AISI 316L

.XX FINISH	.44	.43
.44 SATIN		
.43 BRIGHT		
LRV light reflectance value	53	70

SEAT STANDARD FINISH

WHITE	
BLACK	

Other colors on request - minimum quantity required



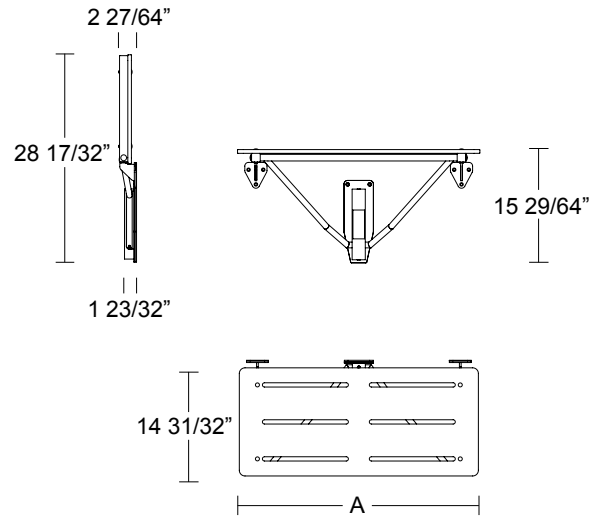

ITEM	A
4CS.447.UR01 . xx	21"
4CS.447.UR02 . xx	27"
4CS.447.UR03 . xx	33"

FOLDING SHOWER SEAT

Seat 1/2" (13 mm) thick solid high pressure laminated (HPL) with slots for water drainage, connected to frame with type-316 stainless steel bolts.

Frame type-316L satin finish stainless steel 1-1/4" (30 mm) square tube connected with 25/32" (20 mm) diameter tube.

Mounting flanges and Guide Bracket in type-316L satin finish stainless steel 15/64" (6 mm) thick with fully recyclable polyamide-6 wall protection. 9 screw holes for attachment to wall.

Adjustable frictioning system.

For installation see page 174.

MOUNTING KITS not included.

Optional mounting kit for concrete, natural stone, solid brick and hollow brick: KIT 4CN.0VM.0042.00.

Optional mounting kit for sheetrock wall and wooden plate: KIT 4CN.0VM.0043.00.

See Technical Data Sheet for load capacity

This product contributes to LEED® credits

STAINLESS STEEL AISI 316L

.XX FINISH	.44	.43
.44 SATIN		
.43 BRIGHT		
LRV light reflectance value	53	70

SEAT STANDARD FINISH

WHITE	
BLACK	

Other colors on request - minimum quantity required



HPL SEAT PANEL FOR 316L STAINLESS STEEL 4CS SEAT

STANDARD COLORS

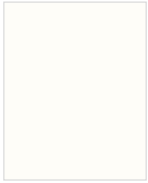

White Megeve

Black

AVAILABLE COLORS (minimum quantity requested)

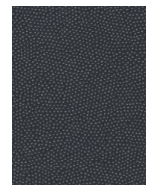

Anise Flower

Green Apple

Cactus

Bali Green

Imperial Green

Teal Green

Caviar

Storm Gray

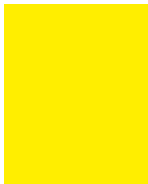

Lemon Zest

Broom

Vinyl

Florida

Nasturtium

Red Amaranth

Mink Gray

Moon Stone



Sambra Yellow

Fatal Red

Red Cherry

Indian Pink

Pink Bougainvillea

Cyclamen

Nutmeg

Natural Beige

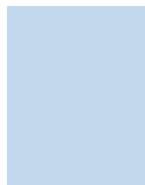
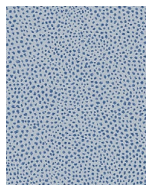

Velvet Blue

Thistle

Indigo Zest

Oslo Blue

Flash Blue

Caribbean Blue

Ash Gray

Pearl Gray

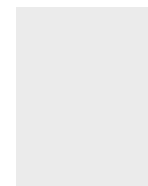
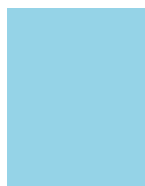

Emerald

Mousse

Celadon

Big Blue

Turquoise

Batik Blue

Paloma Gray

Dove Gra

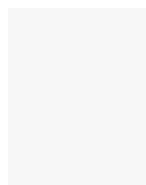
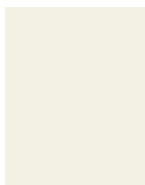
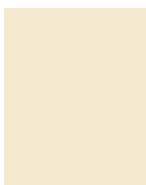
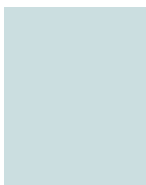

Cocco Zest

Blue Mist

Eggo Shell

Orgeat

White Menuires



SHOWER ACCESSORIES

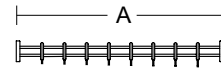

Anodized aluminum
 Polyamide 6

ITEM	A	
4CA.429.001U . xx	32"	8
4CA.429.002U . xx	36"	9
4CA.429.003U . xx	42"	10
4CA.429.004U . xx	48"	12
4CA.429.005U . xx	60"	15
4CA.429.006U . xx	72"	18

SPARE PART

4CN.0AN.0002 . xx
Shower curtain ring



page 168

Concealed mounting flange in stainless steel



WALL TO WALL SHOWER CURTAIN RAIL

Rail 3/32" (2,5 mm) thick EN AW-6060 aluminum extruded and anodized with 1-3/8" (Ø35 mm) outer diameter connected with 3-3/16" (Ø 80 mm) flanges.





Cover in EN AW-6060 anodized aluminum. Mounting flanges with steel core 1/8" (3 mm) thickness and fully recyclable polyamide-6 wall protection. Each cover snaps over mounting flange to conceal mounting screws.

Fully recyclable polyamide-6 curtain rings included.





For maintenance see page 128.

MOUNTING KITS included.

ALUMINUM

.XX FINISH	.78	.70	.79	.73
				

ANODIZED ALUMINUM TRANSPARENT POWDER COATED

.99	.99	.99	.99
			

A M C

This product contributes to LEED® credits



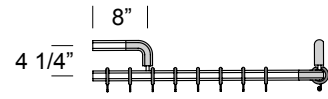

- Anodized aluminum
- Powder coated aluminum alloy
- Polyamide 6

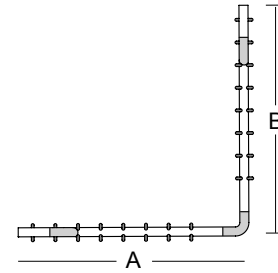

Dimensions: center to center

ITEM	A	B	
4CA.436.0P1U . xx	32"	32"	16

SPARE PART

4CN.0AN.0002 . xx
 Shower curtain ring







page 168

CORNER SHOWER CURTAIN RAIL WITH WALL SUPPORTS





Rail 3/32" (2,5 mm) thick EN AW-6060 aluminum extruded and anodized with 1-3/8" (Ø35 mm) outer diameter. Die-cast aluminum bends with cathoresis pre-treatment and powder-coated finishing. Fully recyclable polyamide-6 curtain rings included. For maintenance see page 128.

MOUNTING KITS included.

ALUMINUM

.XX FINISH	.78	.70	.79	.73
				

ANODIZED ALUMINUM TRANSPARENT POWDER COATED

.99	.99	.99	.99
			



This product contributes to LEED® credits



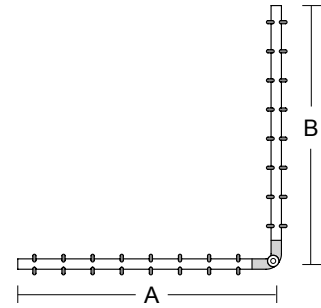
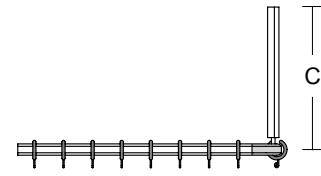

- Anodized aluminum
- Powder coated aluminum alloy
- Polyamide 6

Dimensions: center to center

ITEM	A	B	C	
4CA.436.0B1U .xx	32"	32"	17"	16
4CA.436.0B2U .xx	36"	36"	17"	18
4CA.436.0B3U .xx	42"	42"	17"	20

SPARE PART

4CN.0AN.0002 . xx
 Shower curtain ring



page 168

CORNER SHOWER CURTAIN RAIL WITH WALL SUPPORT

Rail 3/32" (2,5 mm) thick EN AW-6060 aluminum extruded and anodized with 1-3/8" (Ø35 mm) outer diameter. Die-cast aluminum bends with cathophoresis pre-treatment and powder-coated finishing. Fully recyclable polyamide-6 curtain rings included. For maintenance see page 128.

MOUNTING KITS included.

ALUMINUM

.XX FINISH .78 .70 .79 .73



ANODIZED ALUMINUM TRANSPARENT POWDER COATED

.99 .99 .99 .99





This product contributes to LEED® credits

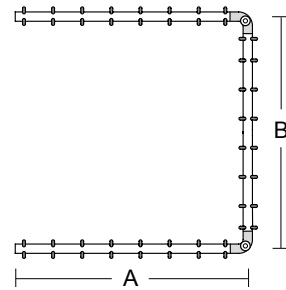
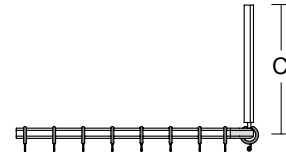



- Anodized aluminum
- Powder coated aluminum alloy
- Polyamide 6

Dimensions: center to center

ITEM	A	B	C	
4CA.437.001U . xx	32"	32"	17"	24

SPARE PART

4CN.0AN.0002 . xx
Shower curtain ring







page 168

THREE SIDES CURTAIN RAIL WITH CEILING SUPPORT





Rail 3/32" (2,5 mm) thick EN AW-6060 aluminum extruded and anodized with 1-3/8" (Ø35 mm) outer diameter. Die-cast aluminum bends with cathoresis pre-treatment and powder-coated finishing. Fully recyclable polyamide-6 curtain rings included. For maintenance see page 128.

MOUNTING KITS included.

ALUMINUM

.XX FINISH	.78	.70	.79	.73
				

ANODIZED ALUMINUM TRANSPARENT POWDER COATED

.99	.99	.99	.99
			

A M C

This product contributes to LEED® credits



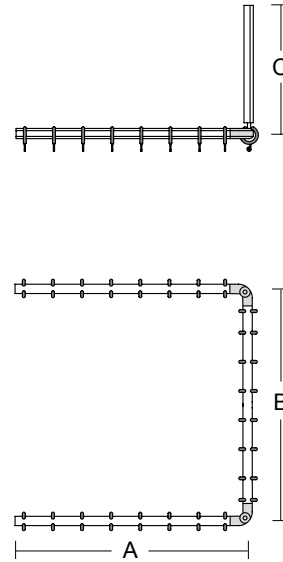

- Anodized aluminum
- Powder coated aluminum alloy
- Polyamide 6

Dimensions: center to center

ITEM	A	B	C	
4CA.437.0B1U .xx	32"	32"	17"	24

SPARE PART

4CN.0AN.0002 .xx
Shower curtain ring



page 168

THREE SIDES CURTAIN RAIL WITH DOUBLE CEILING SUPPORT

Rail 3/32" (2,5 mm) thick EN AW-6060 aluminum extruded and anodized with 1-3/8" (Ø35 mm) outer diameter. Die-cast aluminum bends with cathoresis pre-treatment and powder-coated finishing. Fully recyclable polyamide-6 curtain rings included. For maintenance see page 128.

MOUNTING KITS included.

ALUMINUM

.XX FINISH .78 .70 .79 .73



ANODIZED ALUMINUM TRANSPARENT POWDER COATED

.99 .99 .99 .99



This product contributes to LEED® credits



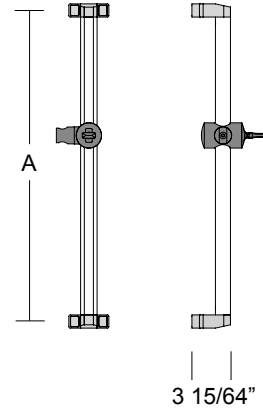

- Anodized aluminum
- Powder coated aluminum alloy
- Polyamide 6

ITEM	A
4CA.487.001U .xx	18"
4CA.487.002U .xx	24"
4CA.487.003U .xx	30"
4CA.487.004U .xx	36"
4CA.487.005U .xx	42"

SPARE PART

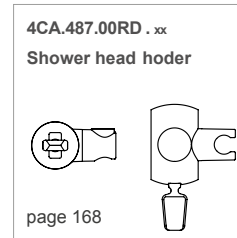

VERTICAL SHOWER HEAD HOLDER RAIL

Rail 3/32" (2,5 mm) thick EN AW-6060 aluminum extruded and anodized with 1-3/8" (Ø35 mm) outer diameter.
 Wall support 3-11/32" x 1-7/64" (85 x 28 mm) in zinc alloy with cathaphoresis pre-treatment and powder-coated finishing.
 Fully recyclable polyamide-6 caps which snap over fixing holes to conceal mounting screws.
 Adjustable fully recyclable polyamide-6 shower head holder included.
 For installation see page 172. For maintenance see page 128.

MOUNTING KITS not included.

Optional mounting kit for concrete, natural stone, solid brick and hollow brick: KIT 4CN.0VM.0030.00.
 Optional mounting kit for sheetrock wall and wooden plate: KIT 4CN.0VM.0032.00.
 One mounting kit is required for each wall support - see page 172.

ALUMINUM

.XX FINISH	.78	.70	.79	.73
				

This product contributes to LEED® credits





WASHROOM ACCESSORIES

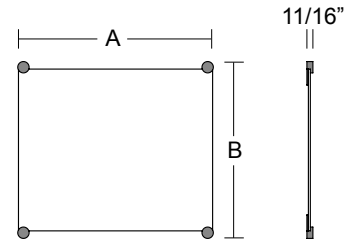

■ Polyamide 6

ITEM	A	B
4CN.490.000R . xx	23 5/8"	21 21/32"
4CN.490.00QR . xx	23 5/8"	27 9/16"
4CN.490.00AR . xx	23 5/8"	39 3/8"

SPARE PART

4CN.490.0WHR. xx
Kit mirror-holder supports

page 168

FIXED MIRROR WITH POLYAMIDE-6 HOLDERS

Crystal glass 15/64" (6 mm) thickness mirror pane attached to wall with 4 fully recyclable polyamide-6 wall supports included. Mounting kit for solid brick / concrete included.

POLYAMIDE 6

.XX FINISH	.78	.70	.17	.10

This product contributes to LEED® credits

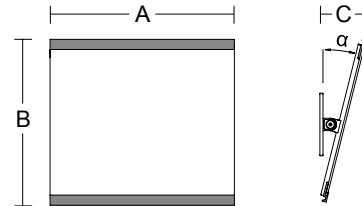

■ Anodized aluminum

ITEM	A	B	C	α
4CA.470.0000 .xx	23 5/8"	21 17/64"	6 19/64"	14°
4CA.470.000Q .xx	23 5/8"	27 11/64"	7 51/64"	14°

ADJUSTABLE MIRROR WITH ANODIZED ALUMINUM FRAME

Adjustable crystal glass 15/64" (6 mm) thickness mirror pane with anodized aluminum frame. Mounting plate in fully recyclable polyamide-6 with diecast zamak 15 and adjustable friction. 4 screws holes for attachment to wall. Mounting kit for solid brick / concrete included.

ALUMINUM

.XX FINISH	.78	.70	.79	.73

ANODIZED ALUMINUM TRANSPARENT POWDER COATED

.99	.99	.99	.99



This product contributes to LEED® credits



TOILET ACCESSORIES

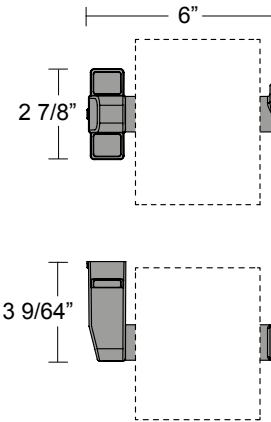

■ Polyamide 6

ITEM

4CA.481.0000 . xx



POLYAMIDE-6 TOILET ROLL HOLDER

Fully recyclable polyamide-6 toilet roll holder with rubber roll braking mechanism. Wall support with fully recyclable polyamide-6 caps to conceal mounting screws. Mounting kit for solid brick / concrete included.

ALUMINUM

.XX FINISH	.78	.70	.79	.73

This product contributes to LEED® credits



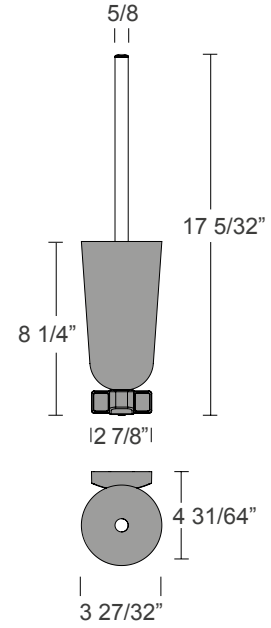

□ Anodized aluminum
 ■ Polyamide 6

ITEM

4CA.486.000C .xx

SPARE PART

4CA.486.00SR .xx
 Spare toilet brush

page 169



SPARE PART

4CN.486.000B .xx
 Spare toilet brush head

page 169



Snap over caps to conceal mounting screws



POLYAMIDE-6 SHELF WITH TOILET BRUSH SET AND ALUMINUM HANDLE

Fully recyclable polyamide-6 tumbler. Wall support with fully recyclable polyamide-6 caps to conceal mounting screws.
 Anodized aluminum handle with toilet brush.
 Mounting kit for solid brick / concrete included.

ALUMINUM

.XX FINISH .78 .70 .79 .73

This product contributes to LEED® credits



SPECIAL ACCESSORIES



PBA
PATENTED
DESIGN

PATENT
IT0000101043

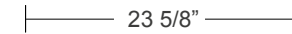
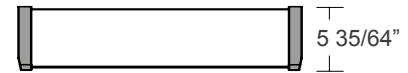
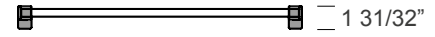

- Anodized aluminum
- Polyamide 6

Dimensions: center to center





ITEM

4CA.484.00AL . xx

ALUMINUM SHELF WITH POLYAMIDE-6 SUPPORTS

Anodized aluminum shelf with fully recyclable polyamide-6 wall support. Mounting kit for solid brick / concrete included.

ALUMINUM

.XX FINISH	.78	.70	.79	.73
				

This product contributes to LEED® credits



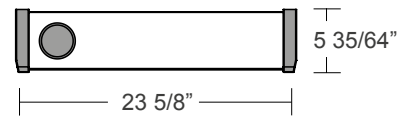
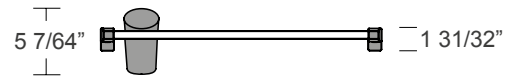

- Anodized aluminum
- Polyamide 6

Dimensions: center to center

ITEM

4CA.485.0IAL .xx

ALUMINUM SHELF WITH POLYAMIDE-6 SUPPORTS AND TUMBLER

Anodized aluminum shelf with fully recyclable polyamide-6 wall support. Fully recyclable polyamide-6 tumbler. Mounting kit for solid brick / concrete included.

ALUMINUM

.XX FINISH	.78	.70	.79	.73

This product contributes to LEED® credits



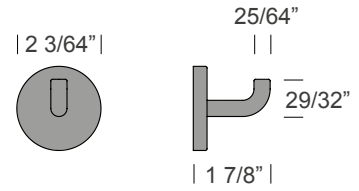

■ Polyamide 6

ITEM

4CN.488.000P . xx

POLYAMIDE-6 CLOTH HOOK

Fully recyclable polyamide-6 curved hook with 25/64" (10 mm) diameter and fully recyclable polyamide-6 flange and cover. Mounting kit for solid brick / concrete included.

POLYAMIDE 6

.XX FINISH	.78	.70	.17	.10

This product contributes to LEED® credits



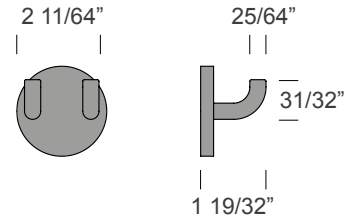

■ Polyamide 6

ITEM





4CN.488.000D .xx

DOUBLE POLYAMIDE-6 CLOTH HOOK

Fully recyclable polyamide-6 double curved hook with 25/64" (10 mm) diameter and fully recyclable polyamide-6 flange and cover.

Mounting kit for solid brick / concrete included.

POLYAMIDE 6

.XX FINISH	.78	.70	.17	.10
				

This product contributes to LEED® credits



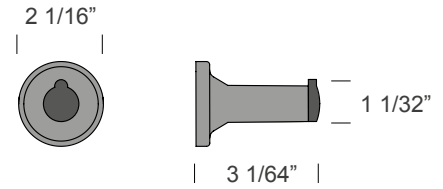

- Polyamide 6
- Black rubber





ITEM

5CN.562.0000 . xx

POLYAMIDE-6 DOOR-STOP CLOTH HOOK

Fully recyclable polyamide-6 hook / door stop with black rubber cap. Fully recyclable polyamide-6 flange and cover. Mounting kit for solid brick / concrete included.

POLYAMIDE 6

.XX FINISH	.78	.70	.17	.10
				

This product contributes to LEED® credits

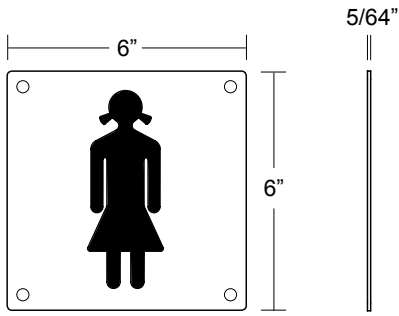

ITEM

2MM.402.0000 . xx

STAINLESS STEEL PLATE WITH LADIES PICTOGRAM

Stainless steel wall plate 5/64" (2 mm) thickness with woman pictogram.

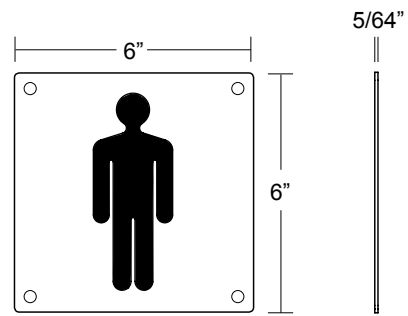

ITEM

2MM.401.0000 . xx

STAINLESS STEEL PLATE WITH GENTLEMEN PICTOGRAM

Stainless steel wall plate 5/64" (2 mm) thickness with man pictogram.

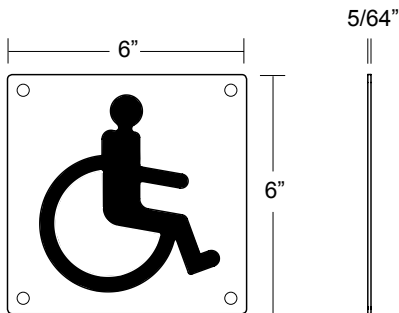

ITEM

2MM.404.0000 . xx

STAINLESS STEEL PLATE WITH INTERNATIONAL SYMBOL OF ACCESSIBILITY PICTOGRAM

Stainless steel wall plate 5/64" (2 mm) thickness with International Symbol of Accessibility pictogram.

STAINLESS STEEL AISI 316L

.XX FINISH	.44	.43
.44 SATIN		
.43 BRIGHT		
LRV light reflectance value	53	70

These products contribute to LEED® credits



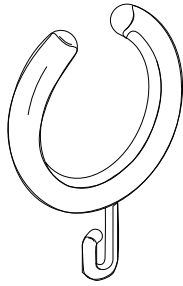

ITEM

4CN.0AN.0002 .xx

SPARE POLYAMIDE-6 CURTAIN RING

Spare fully recyclable polyamide-6 curtain ring.

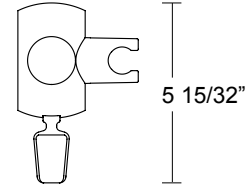
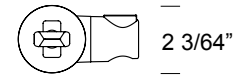

| 3 21/32" |

ITEM

4CA.487.00RD .xx

SHOWER HEAD HOLDER

Shower head holder in polyamide-6, adjustable in height and inclination, can be used one-handed with the control lever. Compatible with the PROGRAMMA 4CA rails.

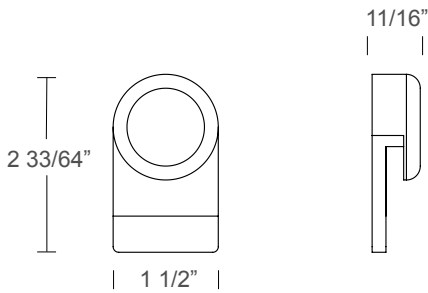

ITEM

4CN.490.0WHR .xx

SPARE POLYAMIDE-6 HOLDERS FOR FIXED MIRROR

Set of 4 fully recyclable polyamide-6 wall supports for fixed mirror

POLYAMIDE 6

.XX FINISH	.78	.70	.17	.10

ALUMINUM

.XX FINISH	.78	.70	.79	.73

These products contribute to LEED® credits



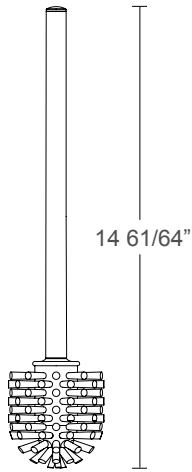

ITEM

4CA.486.00SR .xx

SPARE ALUMUNUM HANDLE FOR TOILET BRUSH SET

Spare anodized aluminum handle with toilet brush.

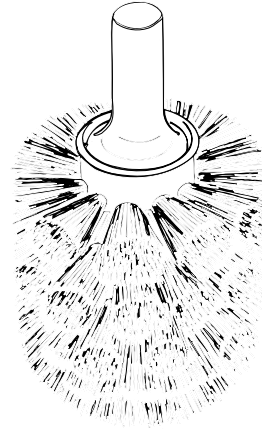





ITEM

4CN.486.000B.00

SPARE TOILET BRUSH HEAD

Spare brush for WC brush set.

ALUMINUM

.XX FINISH	.78	.70	.79	.73
				

These products contribute to **LEED®** credits

TECHNICAL INFORMATION

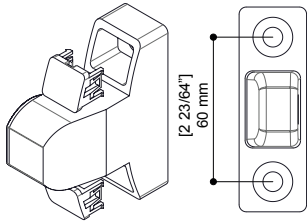

**GRAB BARS FLANGE
MOUNTING INSTRUCTIONS**

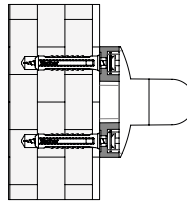

**CONCRETE, NATURAL STONE,
SOLID BRICK, HOLLOW BRICK**





KIT 4CN.0VM.0030.00

- Included:
 2 x plugs
 2 x screws
 2 x brass washers

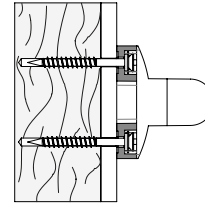
**SHEETROCK WALL,
WOODEN PLATE**



KIT 4CN.0VM.0032.00

- Included:
 2 x brass washers
 2 x screws



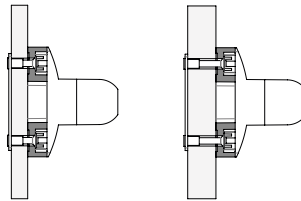

ITEM

GRAB BAR FLANGE
4CA.422, 4CA.433, 4CA.440, 4CA.434

TOILET PARTITION
thickness from 1/2" to 1"



KIT 4CN.0VM.0041.00

- Included:
 1 x stainless steel backing
 3 x 16mm screws for 1/2" panel
 3 x 25mm screws for 3/4" panel
 3 x 30mm screws for 1" panel
 3 x stainless steel nuts

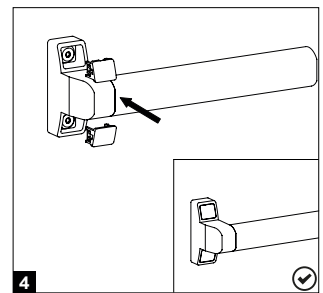
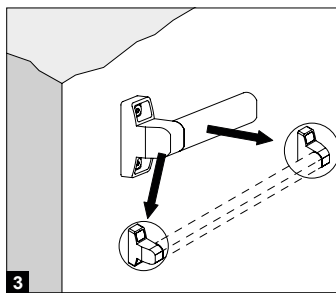
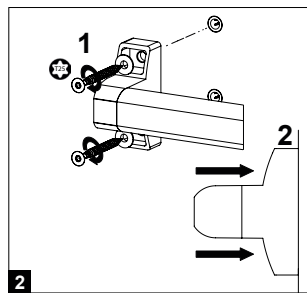
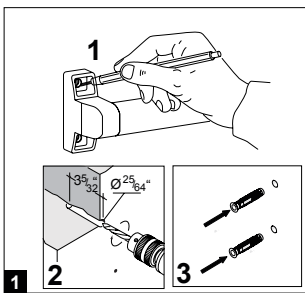

**SWING-UP GRAB BAR
MOUNTING INSTRUCTIONS**

CONCRETE, NATURAL STONE,
SOLID BRICK, HOLLOW BRICK

SHEETROCK WALL,
WOODEN PLATE

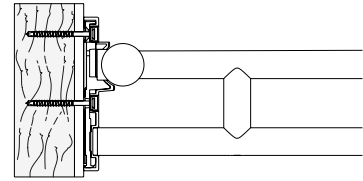
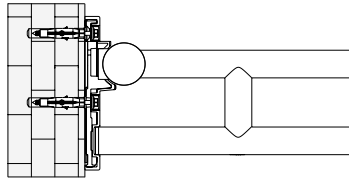
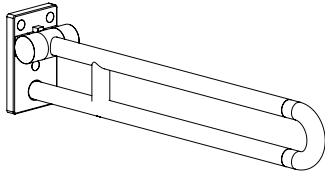

ITEM
SWING-UP GRAB BAR
4CA.445

KIT 4CN.0VM.0014.00
Included:
3 x plugs
3 x screws
3 x brass washers



KIT 4CN.0VM.0017.00
Included:
3 x screws
3 x brass washers

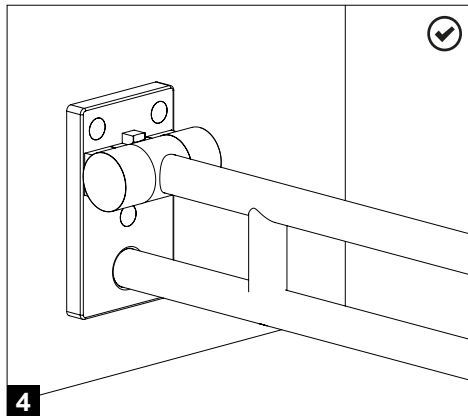
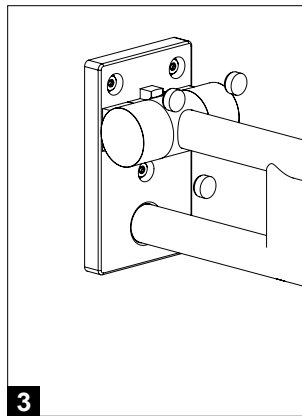
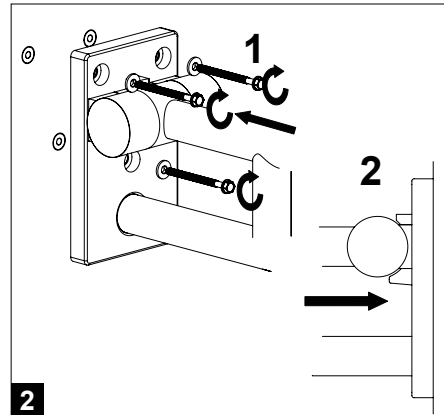
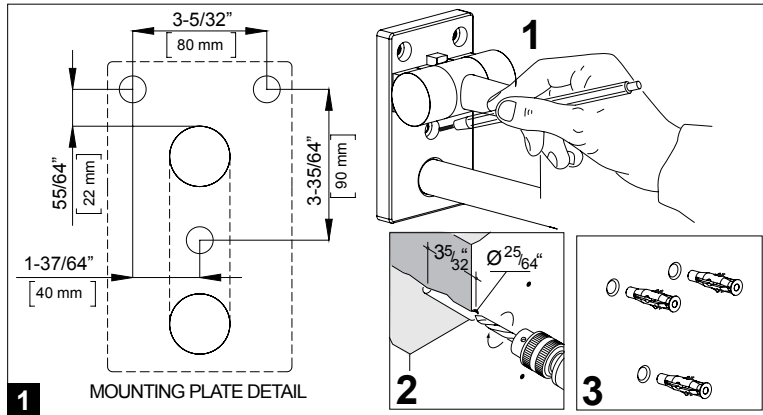

FOLDING SHOWER SEAT
MOUNTING INSTRUCTIONS

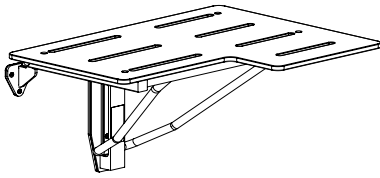

ITEM
FOLDING SHOWER SEAT
4CS.447

CONCRETE, NATURAL STONE,
SOLID BRICK, HOLLOW BRICK

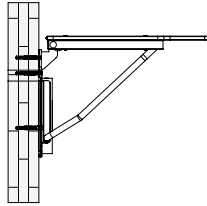

KIT 4CN.0VM.0042.00
Included:
9 x plugs
9 x screws

SHEETROCK WALL,
WOODEN PLATE

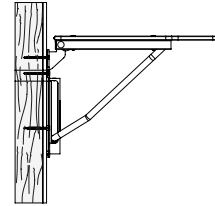

KIT 4CN.0VM.0043.00
Included:
9 x screws

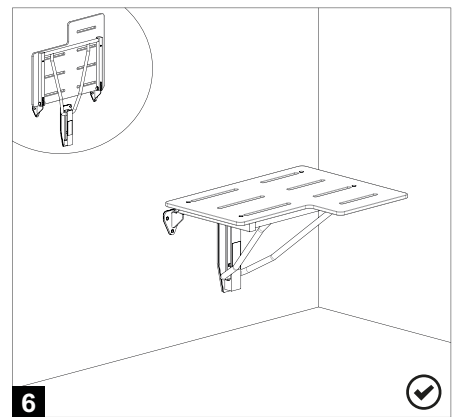
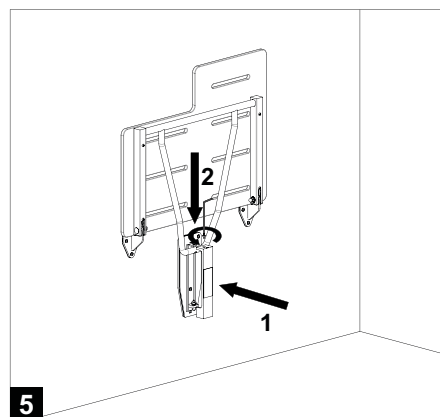
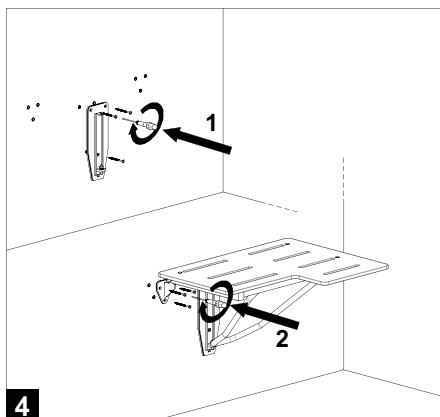
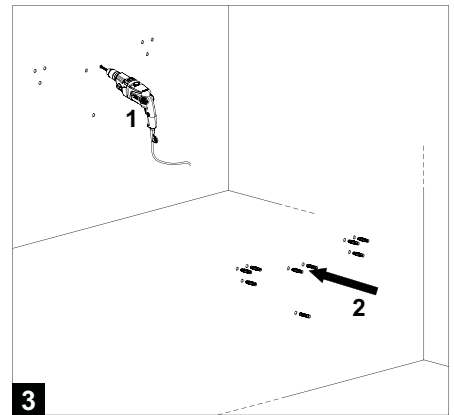
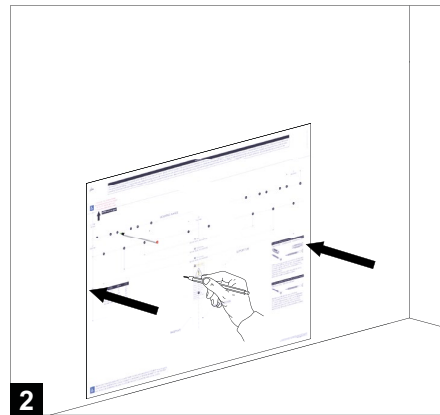
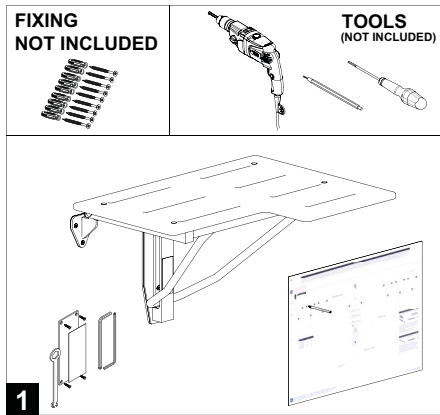

GENERAL CONDITIONS OF SALE

1. AGREEMENT

1.1 The supply of the products shown in this pricelist ("Products") of PBA SpA ("PBA") shall be governed by these general conditions of sale ("General Conditions"). These General Conditions shall apply also to the sale of spare parts, when possible.

1.2 The sale agreement of the Products ("Agreement") is entered into force among the parties upon the Client's receipt of PBA's order confirmation.

These General Conditions shall be deemed as an integral and essential part of any Agreement.

1.3 These General Conditions shall be executed by the Client and attached to the first purchase order sent to PBA, it being agreed that they shall accordingly apply to any following Agreement.

1.4 These General Conditions shall be deemed as tacitly accepted by the Client for any supply of Products, unless expressly rejected in writing by the Client by means of notice thereof to be sent to PBA at the latest within 5 (five) days as of the date of receipt of PBA's confirmation of the first purchase order sent by the Client.

Should the Client expressly reject one or more of these General Conditions within the above term, PBA shall be free to withdraw from the relevant Agreement, by means of written communication thereof and without any further obligation.

1.5 In no event shall any general conditions of any nature, inserted and/or specified in the Client's order forms and/or in other documents sent to PBA by the Client, and/or of which the latter was made aware in any manner whatsoever, apply to any Agreement and/or to any supply of Products.

Any special term and/or condition of supply suggested by the Client shall apply to the Agreement only if expressly contained in PBA's order confirmation.

Any change and/or amendment to these General Conditions shall be binding and valid only if accepted in writing by both parties.

2. PLACE AND TERMS OF DELIVERY OF THE PRODUCTS

2.1 The choice of an Incoterm does not affect the location of the place of delivery of the Products which, in any case, shall be deemed as delivered to the Client at the place and in the moment in which they are put at disposal of the haulier, for the relevant transport, at PBA's premises in Tezze sul Brenta (Vicenza), Italy.

In any case, unless otherwise agreed in writing by the parties, PBA shall never be liable for delays accrued during the transportation.

2.2 The terms of delivery of the Products (i) are specified in PBA's order confirmation, (ii) are approximate and roughly set forth and (iii) in no case shall they be construed as of essence.

2.3 In case of delay in the delivery of the Products at PBA's premises, caused by a fortuitous event, force majeure or other causes not depending on PBA's willful misconduct and/or gross negligence, the Client shall not be entitled to claim any compensation for damages, nor to ask for the termination of the Agreement and/or for the reduction of the price of the Products.

3. INCOTERMS

Unless otherwise agreed in writing, the Products and the relevant prices are to be considered with delivery Ex-works (EXW – Incoterms 2000), PBA's premises in Tezze sul Brenta (VI), Italy or at the different place indicated by PBA in the notice Products ready for delivery.

4. ORDERS – NON STANDARD AND/OR MADE TO MEASURE PRODUCTS

4.1 The purchase orders shall be made in writing and completed with all the data relevant for the relevant design and manufacture.

4.2 When already approved by the Client for the supply of catalogue Products, it is agreed that these General Conditions shall also apply to the sale orders related to non standard Products, Products out of catalogue and/or to be made to measure, if confirmed by PBA.

4.3 Any delay of the Client in the transmission of data, measures and/or technical specifications of the Products subject matter of the Agreement may cause a proportional postponement of the delivery terms, to be newly determined by PBA on the basis of its industrial needs.

5. PRICES AND PAYMENTS

5.1 The prices of the Products indicated in this pricelist are merely indicative and can be modified at any time by PBA.

The actual price of the Products is specified in PBA's order confirmation and, unless otherwise specified, it is deemed as net of VAT.

Any change and/or modification of the Products, agreed by the parties after the transmission of PBA's order confirmation, shall cause the adjustment of the relevant price due to any increase of the costs of production and/or of the raw materials, as agreed from time to time by the parties.

5.2 The price of the Products shall be paid by the Client as per the terms and ways specified in PBA's order confirmation, or otherwise agreed by the parties.

Any late collection or non collection of the Products shall not cause an extension and/or postponement of the terms of payment.

5.3 PBA shall be entitled to suspend the delivery of the Products should:

(a) the Client's assets and/or financial standings endanger the relevant payment; (b) the Client fail to timely pay Products previously supplied by PBA, also on the basis of other Agreements, until full payment of the outstanding credit and/or until receipt of proper guarantees of the Client for any delivery in progress, without prejudice to PBA's right to claim for any damages suffered as a consequence thereof.

5.4 In no event shall any vice and/or defect of the Products, even when expressly acknowledged as such by PBA, and/or any delay of delivery as to the agreed terms give the Client the right to suspend the relevant payments and/or any other payment for whichever reason due to PBA also under other contractual relationships.

5.5 In case of late payments, PBA shall be entitled to charge interests on the unpaid amount at the rate provided by the law.

5.6 In no case shall the Client be entitled to set off any amount due to PBA in force of any Agreement against any amount due by PBA at any title whatsoever.

6. RETENTION OF TITLE

PBA shall be the sole owner of the Products until the date of their full payment.

Should the Agreement be terminated due to the Client's breach of contract, any Client's advance payment shall be kept by PBA as an indemnity within the limits set forth by the law, without prejudice to the latter's right to claim for further damages.

7. WARRANTY

7.1 PBA guarantees that the Products will be free from vices and defects in materials and workmanship for a period of 24 (twenty-four) months as of the date of the relevant delivery ("Warranty Period").

7.2 Should the complaints raised by the Client within the Warranty Period with reference to the Products be grounded and accepted by PBA, the latter shall, at its exclusive discretion, repair and/or replace the defective Product/s or the defective component/s of the same, with delivery Ex-works (EXW Incoterms 2000) PBA's premises in Tezze sul Brenta (VI), Italy.

The warranty obligations herewith undertaken shall be effective and binding only provided that PBA has the opportunity to verify the vices and/or defects raised by the Client.

PBA's warranty obligation shall be deemed as entirely fulfilled with the removal of the vice and/or defect raised by the Client, or with the replacement of the defective Product and/or component, without any further obligations.

Unless otherwise agreed in writing by the parties, all the expenses for returning to PBA the defective Products and/or components, as well as all the additional expenses related to the operations of repair or replacement shall be borne by the Client and shall be at the Client's risk.

7.3 Subject to the loss of warranty, the Client shall notify in writing, by registered letter return receipt requested, any vices and/or defects found within and not later than 8 (eight) days as of the date of the actual delivery of the Products, or, in case of hidden vices or defects, within and not later than 8 (eight) days as of the date of the relevant discovery.

7.4 The warranty is expressly excluded for vices and/or defects of the Products arising from or consisting in:

(i) any repair, alteration and/or modification not authorized in writing by PBA;

(ii) normal wear and tear of the materials or of single components;

(iii) improper use and/or application of the Products;

(iv) defects and/or mistakes in the measures and/or technical specifications supplied by the Client;

(v) deposit, maintenance and/or cleaning not in compliance with PBA's instructions;

(vi) installation not in compliance with PBA's instructions and/or carried out with non suitable materials;

(vii) any other event for which PBA is not directly liable.

Should the Client fail to regularly pay the agreed price, even if such default or such delay concerns a single part of the aggregate price of the Products, the warranty shall not apply.

7.5 Without prejudice to the compulsory product's liability law and any liability for willful misconduct and/or gross negligence, PBA shall not be liable for direct, indirect or incidental damages caused to the Client and and/or to third parties as a consequence of the defects of the Products. The Client shall not be entitled to terminate the Agreement in case of vices and/or defects of the Products subject matter of this warranty, should PBA timely comply with the relevant obligations.

7.6 The Products made of wood, pvc, rubber, rolled sections and/or of other natural materials shall be of a quality equal, within the limits of a reasonable similarity, to the relevant samples examined by the Client before the execution of the Agreement.

In no case shall therefore the samples of the Products examined by the Client be qualified as the exclusive standard for the exterior appearance of the Products.

Without prejudice to the warranty regulated by this clause 7, any chromatic and/or aesthetic difference (nervation of the wood, intensity of the colour shades, etc.) of the delivered Products compared to the characteristics of the relevant samples examined by the Client, shall not entitle the latter to terminate the Agreement and/or to ask for the replacement of the Products or for the reduction of the price.

7.7 In no event shall the chromatic differences between Products of the same type and/or colour, delivered with different lots and/or in different moments, be qualified as vices and/or defects of the Products, nor shall the Client be entitled to claim their replacement and/or the reduction of the relevant price as a consequence thereof.

8. MISPRINTS AND PRINTING ERRORS

We are not responsible for any misprint or printing error in catalogs or price lists. All images and sizes are not binding. Modifications are reserved. Design modifications are reserved to technically enhance products.

9. EXCLUSIVE COURT

All disputes arising out of or relating to these General Conditions, any Agreement and/or to the supply of Products shall be exclusively submitted to and settled by the Court of Vicenza, Italy.

PBA shall in any case be entitled, at its exclusive discretion, to institute legal proceedings against the Client before the Court of the place where the Client has its registered office.

10. APPLICABLE LAW

These General Conditions of sale and any Agreement shall be governed by Italian Law.

Should the Client be a foreign entity or in any case an entity having the registered office or the main place of business abroad, the Contracts related to the supply of the Products shall in any case be regulated by the United Nations Convention on the International Sale of Goods (Wien Convention, April 11, 1980)

11. WAIVER

Failure by PBA to enforce at any time the provisions of these General Conditions shall not be construed as a waiver of such provision or of the right to thereafter enforce each and every provision herein.

12. LANGUAGE

The Client executes these General Conditions in Italian and in English, it being agreed that should any conflict or inconsistency arise among the two versions, the Italian wording shall always prevail.

pba S.p.A.

T +39 0424 5451 info@pba.it www.pba.it

pba USA, Inc.

T +1 212 255 4605 office@pba-usa.us www.pba.it

pba S.p.A. Deutschland

T +49 2151 820060 info@de.pba.it www.pba.it