

poa



M A D E  
I N I T A L Y

HOSPITALITY

poa

SIAMO QUELLI CHE APRONO LE PORTE DELLE UNIVERSITÀ, DEI NEGOZI, DEGLI OSPEDALI, DEGLI EDIFICI CHE DA LUOGHI SONO DIVENTATI ICONE. SIAMO QUELLI CHE “ANCHE UNA MANIGLIA DICE CHI SIAMO QUINDI, FACCIAMOLA AL MEGLIO”, QUELLI CHE “LA SOSTENIBILITÀ È COERENZA CHE SI MOSTRA NEL LUNGO PERIODO QUINDI, PRESTIAMO ATTENZIONE ADESSO”. QUELLI CHE RENDONO BELLA LA FUNZIONE DI UN PUNTO D’APPOGGIO IN UNA STANZA DA BAGNO, DI UN’IMPUGNATURA DI UN CASSETTO. FORTI COME L’ACCIAIO E SEMPRE IN CAMBIAMENTO COME IL RAME. SIAMO QUELLI CHE VI FANNO ENTRARE, USCIRE, ANDARE, RIMANERE E RITORNARE. SIAMO QUELLI DEL FARE MAI TANTO PER FARE, SEMPRE MOSSI DALL’AMBIZIONE DI CREARE OGGETTI “BUONI” PER OGNUNO E PER TUTTI.

WE ARE THE ONES WHO OPEN DOORS OF UNIVERSITIES, STORES, HOSPITALS, AND BUILDINGS, THAT SHIFTED FROM PLACES TO ICONS. WE ARE THE ONES WHO “EVEN A PULL TELLS WHO WE ARE, SO LET’S DO IT EVEN BETTER”; THOSE WHO “SUSTAINABILITY IS CONSISTENCY UNVEILING IN THE LONG TERM, SO LET’S PAY ATTENTION NOW”. WE ARE THE ONES WHO EMBELLISH THE FUNCTION OF A GRAB BAR IN A BATHROOM, OF A DRAWER PULL. STRONG AS STEEL, CONSTANTLY-CHANGING AS COPPER. WE ARE THE ONES WHO LET YOU IN AND OUT, GO, STAY AND COME BACK. WE ARE THE ONES WHO NEVER MAKE JUST FOR THE SAKE OF MAKING, BUT ALWAYS MOVED BY THE AMBITION OF CREATING “GOOD” OBJECTS FOR ALL.

NOUS SOMMES CEUX QUI OUVRONT LES PORTES DES UNIVERSITÉS, DES MAGASINS, DES HÔPITAUX, DES IMMEUBLES QUI SONT DEVENUS DES ICÔNES. NOUS SOMMES CEUX QUE “AUSSI UNE SIMPLE BÉQUILLE EXPLIQUE QUI NOUS SOMMES ET PORTANT FAISONS-LA AU MIEUX”, NOUS SOMMES CEUX QUE “LA DURABILITÉ SE TRADUIT EN COHÉRENCE DANS LA LONGUE PÉRIODE ET PORTANT NOUS PRÊTONS ATTENTION AUJOURD’HUI”. NOUS SOMMES CEUX QUI RENDENT BELLE LA FONCTION D’UNE BARRE D’APPUI DANS UNE SALLE DE BAIN, D’UNE POIGNÉE DANS UN TIROIR. NOUS SOMMES FORTS COMME L’ACIER ET TOUJOURS EN CHANGEMENT COMME LE CUIVRE. NOUS SOMMES CEUX QUI VOUS FONT ENTRER, SORTIR, ALLER, RESTER ET RENTRER. NOUS SOMMES CEUX DE JAMAIS FAIRE POUR RIEN ET TOUJOURS POUSSÉS PAR L’AMBITION DE CRÉER DES OBJETS “UTILES” POUR TOUS.

WIR SIND DIEJENIGEN, DIE DIE TÜREN VON UNIVERSITÄTEN, GESCHÄFTEN, KRANKENHÄUSERN UND GEBÄUDEN ÖFFNEN, DIE VON ORTEN ZU IKONEN GEWORDEN SIND. WIR SIND DIEJENIGEN, DIE SAGEN WER WIR SIND UND ES BESSER MACHEN. DIE „NACHHALTIGKEIT IST BESTÄNDIGKEIT, DIE SICH LANGFRISTIG ZEIGT, ALSO LASST UNS JETZT AUFPASSEN“. DIE, DIE DIE FUNKTION EINES ORTES IM BADEZIMMER ODER EINES SCHUBLADENGRIFFS SCHÖN MACHEN. STARK WIE EDELSTAHL UND IMMER IM WANDEL WIE KUPFER. WIR SIND DIEJENIGEN, DIE SIE EIN- UND AUSSTEIGEN LASSEN, GEHEN, BLEIBEN UND ZURÜCKKEHREN. UNS TREIBT IMMER DER EHRGEIZ AN, GUTE OBJEKTE FÜR JEDEN UND ALLEN ZU SCHAFFEN.

SOMOS LOS QUE ABREN LAS PUERTAS DE LAS UNIVERSIDADES, DE LAS TIENDAS, DE LOS HOSPITALES, DE LOS EDIFICIOS QUE COMO LUGARES SE HAN CONVERTIDO EN MODELOS. SOMOS LOS QUE “TAMBIÉN UNA MANILLA DICE QUIÉN SOMOS, ENTONCES, HAGAMOS-LA DE LA MEJOR MANERA”, LOS QUE “LA SOSTENIBILIDAD ES COHERENCIA QUE SE MUESTRA EN EL LARGO PLAZO, ENTONCES CUIDAMOS AHORA”. LOS QUE HACEN HERMOSA LA FUNCIÓN DE UN APOYO EN UN CUARTO DE BAÑO, DE UNA EMPUÑADURA DE UN CAJÓN. FUERTES COMO EL ACERO Y SIEMPRE EN TRANSFORMACIÓN COMO EL COBRE. SOMOS LOS QUE OS HACEN ENTRAR, SALIR, IR, QUEDAR Y VOLVER. SOMOS LOS QUE NO HACEN SOLO PARA HACER, PORQUE SIEMPRE LO QUE NOS MUEVE ES LA AMBICIÓN DE CREAR OBJETOS “BUENOS” PARA CADA UNO Y PARA TODOS.

AN's BEST OF PRODUCTS AWARDS  
WINNER



NYCXDESIGN AWARDS  
FINALIST



EUROPEAN PRODUCT DESIGN AWARD  
HONORABLE MENTION



#METROPOLISLIKES NYCXDESIGN  
WINNER



GLOBAL FUTURE DESIGN AWARDS  
THIRD AWARD



V ADI CERAMICS & BATHROOM  
DESIGN AWARD  
SPECIAL MENTION





EPD ENVIRONMENTAL PRODUCT DECLARATION

IL NOSTRO CONTRIBUTO ALLA TUTELA DELL'ECOSISTEMA. pba HA OTTENUTO LA CERTIFICAZIONE AMBIENTALE DI PRODOTTO EPD DALL' INTERNATIONAL EPD SYSTEM. UNA EPD (ENVIRONMENTAL PRODUCT DECLARATION) È UNA DICHIARAZIONE VERIFICATA E REGISTRATA CHE COMUNICA INFORMAZIONI TRASPARENTI E COMPARABILI SUL CICLO DI VITA E SULL'IMPATTO AMBIENTALE DI UN PRODOTTO. LA DICHIARAZIONE È BASATA SU UNO STUDIO LCA (LIFE CYCLE ASSESSMENT), SVILUPPATO SECONDO REGOLE PRESTABILITE ED È PREDISPOSTA SECONDO LA ISO 14025 E LA ISO 21930. I CONTENUTI DELLE DICHIARAZIONI EPD SONO VERIFICATE E VALIDATE DA TERZE PARTI.

OUR CONTRIBUTION TO THE PROTECTION OF THE ECOSYSTEM. pba HAS OBTAINED THE EPD VALIDATION AND REGISTRATION FROM THE INTERNATIONAL EPD SYSTEM. AN ENVIRONMENTAL PRODUCT DECLARATION (EPD) IS AN ISO TYPE III ENVIRONMENTAL DECLARATION BASED ON ISO 14025 STANDARD. AN EPD TRANSPARENTLY REPORTS THE ENVIRONMENTAL PERFORMANCE OF PRODUCTS OR SERVICES FROM A LIFECYCLE PERSPECTIVE. THE PREPARATION OF AN EPD INCLUDES DIFFERENT STAGES, FROM ACQUIRING RAW MATERIALS TO THE END OF LIFE OF THE FINAL PRODUCT. EPDS ARE BASED ON INTERNATIONAL STANDARDS AND CONSIDER THE ENTIRE VALUE CHAIN. ADDITIONALLY, EPD IS A THIRD-PARTY VERIFIED DOCUMENT.

 **EPD**®  
THE INTERNATIONAL EPD® SYSTEM



## LEED

IL NOSTRO CONTRIBUTO ALL'EFFICIENZA E ALLA SOSTENIBILITÀ DEGLI EDIFICI. LEED (LEADERSHIP IN ENERGY ENVIRONMENTAL DESIGN) È UN SISTEMA DI CERTIFICAZIONE A BASE VOLONTARIA PER LA GESTIONE, LA PROGETTAZIONE E LA COSTRUZIONE DI EDIFICI SOSTENIBILI DAL PUNTO DI VISTA SOCIALE, AMBIENTALE, ECONOMICO E DEL BENESSERE PER GLI UTILIZZATORI. I PRODOTTI pba CONTRIBUISCONO AI PREREQUISITI E AI CREDITI LEED.

OUR CONTRIBUTION TO THE EFFICIENCY AND SUSTAINABILITY OF BUILDINGS. LEED (LEADERSHIP IN ENERGY ENVIRONMENTAL DESIGN) IS A VOLUNTARY CERTIFICATION SYSTEM FOR THE MANAGEMENT, DESIGN AND CONSTRUCTION OF BUILDINGS THAT ARE SUSTAINABLE FROM A SOCIAL, ENVIRONMENTAL AND ECONOMIC POINT OF VIEW AND IN TERMS OF THE WELLBEING OF THE USERS. pba PRODUCTS CONTRIBUTE TOWARD SATISFYING PREREQUISITES AND CREDITS UNDER LEED.

---

PROCESSO INTEGRATO  
INTEGRATED PROCESS

**IP**



---

MATERIALI E RISORSE  
MATERIALS AND RESOURCES

**MR**



---

QUALITÀ DELL'AMBIENTE INTERNO  
INDOOR ENVIRONMENTAL QUALITY

**EQ**



---

INNOVAZIONE  
INNOVATION

**IN**



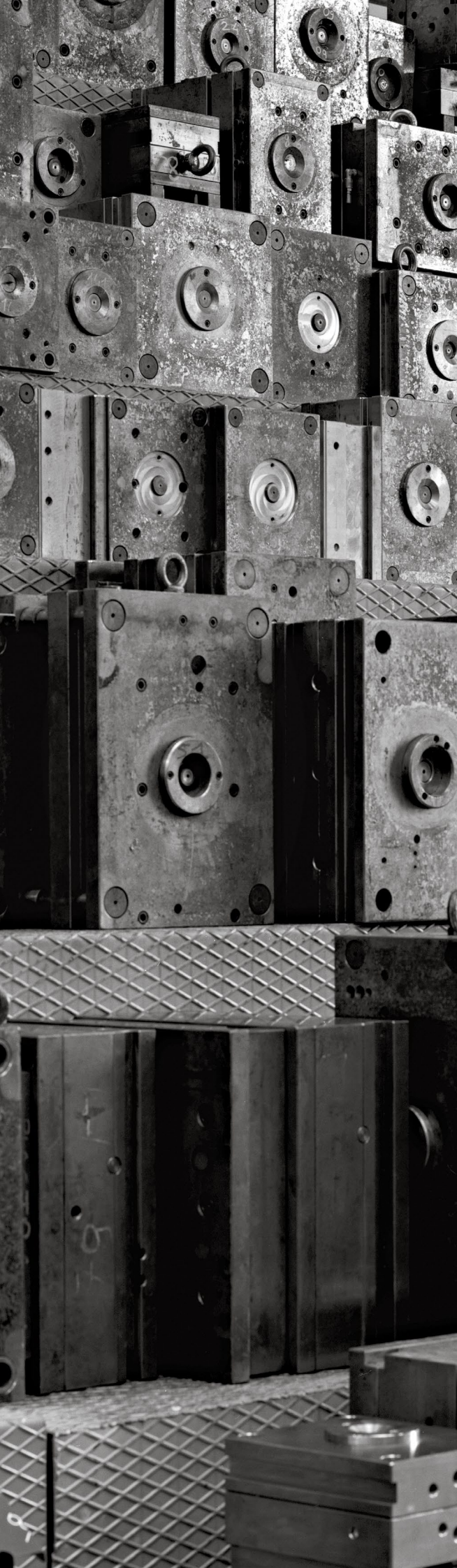

## DECLARE LABEL

I NOSTRI PRODOTTI “RED LIST FREE” PER EDIFICI SOSTENIBILI. L’ETICHETTA DECLARE ELENCA I MATERIALI UTILIZZATI NEL PRODOTTO CON LO SCOPO DI FAR SAPERE DI COSA SONO FATTI, DOVE VENGONO PRODOTTI E COME VERRANNO SMALTITI. L’ETICHETTA DECLARE È UN INVITO ALLA RESPONSABILITÀ SIA PER I PRODUTTORI CHE PER GLI UTILIZZATORI. LA DECLARE LABEL È UNA GUIDA PER SELEZIONARE I PRODOTTI, FORNISCE INFORMAZIONI IN MODO SEMPLICE E TRASPARENTE E METTE IN SOFFITTA IL GREENWASHING. DECLARE, PER DEFINIRE E DICHIARARE CHE I PRODOTTI SONO PRIVI DI SOSTANZE CHIMICHE DANNOSE, FA COMPLESSE ANALISI CHIMICHE E REPERISCE INFORMAZIONI A PARTIRE DALLA FONTE DELLE MATERIE PRIME. TUTTE LE DECLARE LABEL DEI PRODOTTI pba SONO RED LIST FREE.

OUR DECLARE “RED LIST FREE” PRODUCTS FOR SUSTAINABLE BUILDINGS. THE DECLARE LABEL LISTS THE MATERIALS IN A PRODUCT TO DISCLOSE WHAT THEY ARE MADE OF, WHERE THEY ARE PRODUCED AND HOW THEY WILL BE DISPOSED OF. THIS LABEL IS A CALL FOR RESPONSIBILITY TO PRODUCERS AND USERS ALIKE. THE DECLARE LABEL IS A GUIDE TO SELECT PRODUCTS, PROVIDES INFORMATION IN A SIMPLE AND TRANSPARENT WAY AND RISES ABOVE GREENWASHING. DECLARE TAKES COMPLEX CHEMICAL ANALYSIS AND RAW MATERIAL SOURCE LOCATION INFORMATION TO ESTABLISH THAT PRODUCTS ARE FREE FROM HAZARDOUS CHEMICALS. ALL DECLARE LABEL OF pba PRODUCTS ARE RED LIST FREE.

**Declare.**<sup>SM</sup>





CAP NASCE DALL'INTUIZIONE ESTETICA DI VOLER VEDERE IL MONDO PER CIÒ CHE NON È ANCORA. CAP È UNA SERIE DI AUSILI A SCOMPARSA IN ALLUMINIO VERNICIATO CHE IN POSIZIONE DI NON UTILIZZO, SCOMPAIONO ALLO SGUARDO. È IL LORO "SCOMPARIRE" A SVELARNE IL SIGNIFICATO. QUI IL DESIGN È AUTENTICAMENTE PER TUTTI PERCHÉ SULLO SFONDO NON SI IMPONE IL PROFILO DI UN UTENTE DEFINITO BENSÌ, UNICAMENTE, IL MUOVERSI LIBERO DI UOMINI.

CAP ORIGINATES FROM AN INTUITION IN DESIGN WITH A DESIRE TO SEE THE WORLD FOR WHAT IT COULD BE. CAP IS A SERIES OF FOLDAWAY AIDS IN COATED ALUMINIUM THAT, IF NOT IN USE, DISAPPEAR FROM VIEW. IT IS THIS "DISAPPEARANCE" THAT REVEALS THEIR TRUE MEANING. HERE DESIGN IS GENUINELY FOR EVERYONE, BECAUSE THE OVERALL INTERIOR DESIGN IS NOT UNDERPINNED BY A SPECIFIC USER PROFILE, BUT SOLELY BY THE FREE MOVEMENT OF MEN.

CAP VIENT DE L'INTUITION ESTHÉTIQUE DE LA VOLONTÉ DE VOIR LE MONDE POUR CE QUI N'EST PAS ENCORE DÉVOILÉ. CAP COMPREND UNE SÉRIE D'ÉLÉMENTS ESCAMOTABLES EN ALUMINIUM PEINT QUI SONT DISSIMULÉS DU REGARD S'ILS NE SONT PAS UTILISÉS. C'EST LEUR CARACTÉRISTIQUES DE "DISPARAÎTRE" QUI EN DÉVOILE LE SENS. ICI, LE DESSIN EST AUTHENTIQUE ET CONÇU POUR TOUT LE MONDE CAR, AU FOND, IL N'Y A PAS DE PROFIL D'UN UTILISATEUR SPÉCIFIQUE QUI S'IMPOSE MAIS PLUTÔT LA LIBRE ET UNIQUE CIRCULATION DE PERSONNES.

CAP WURDE AUS DER IDEE GEBOREN, DIE WELT SEHEN ZU WOLLEN, WIE SIE NOCH NICHT IST. CAP IST EINE SERIE BARRIEREFREIER PRODUKTE AUS BESCHICHTETEM ALUMINIUM, DIE AUS DEM BLICKFELD VERSCHWINDEN, WENN SIE NICHT BENÖTIGT WERDEN UND DAMIT IHRE EIGENTLICHE FUNKTION NICHT ZEIGEN. DAS DESIGN BERÜCKSICHTIGT DAS ÄSTHETISCHE EMPFINDEN ALLER UND NICHT NUR DER MENSCHEN, DIE DIESE PRODUKTE NUTZEN.

CAP NACE A RAÍZ DE UNA INTUICIÓN ESTÉTICA QUE QUIERE VER EL MUNDO COMO TODAVÍA NO ES. CAP ES UNA SERIE DE AYUDAS RETRÁCTILES DE ALUMINIO PINTADO QUE, EN POSICIÓN DE NO UTILIZACIÓN, DESAPARECEN DE LA VISTA. ES SU «DESAPARICIÓN» LA QUE REVELA SU SIGNIFICADO. EL DISEÑO ES VERDADERAMENTE PARA TODOS, PORQUE EN EL FONDO NO SE IMPONE EL PERFIL DE UN USUARIO DEFINIDO, SINO ÚNICAMENTE LA LIBERTAD DE MOVIMIENTO DE LAS PERSONAS.





BATHROOM FOLDAWAY AIDS

Extruded, die-cast and  
powder coated aluminium





BATHROOM FOLDAWAY AIDS

Extruded, die-cast and  
powder coated aluminium





ART.	A	B	C	D
CAP.447.000B .xx	460*	340*	450*	390*

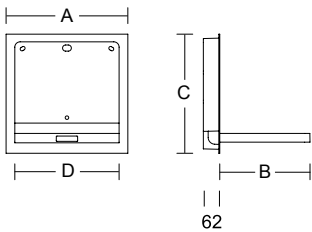

- Seggiolino ribaltabile a scomparsa
- Lift-up foldaway shower seat
- Siège relevable escamotable
- Klappsitz, versenkbar für Wandeinbau
- Asiento abatible retráctil



**POWDER COATED ALUMINIUM**

.XX STANDARD FINISH	.30	.24

Colori a richiesta: lotti minimi da concordare - Colours on demand: minimum lot to be agreed  
 Couleurs sur demande: lots minimum à convenir - Weitere Farben: auf Anfrage, mengenabhängig  
 Colores requeridos: lotes minimos a convenir



ART.	A	B
4CN.447.00CM .xx	400*	415*
4CN.47K.00CM .xx	400*	415*

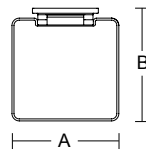
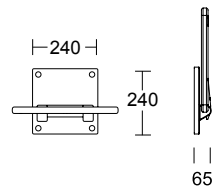

- Seggiolino ribaltabile in nylon con seduta morbida
- Lift-up nylon soft seat
- Siège relevable en nylon avec assise souple
- Opklapbare douchezit in nylon met zachte zit
- Asiento abatible de nylon con superficie mullida



**NYLON**

.XX STANDARD FINISH	.01	.07



ART.	A	B
CAP.445.000T . xx	600*	852*
CAP.445.0000 . xx	700*	952*
CAP.445.000L . xx	850*	1102*

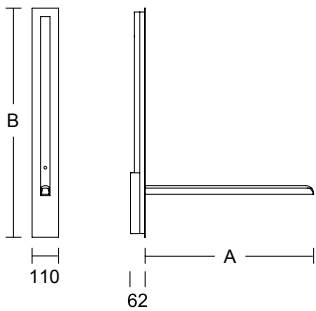

- Sostegno di sicurezza ribaltabile a scomparsa
- Lift-up foldaway safety support
- Barre d'appui relevable escamotable
- Stützklappgriff, versenkbar für Wandeinbau
- Asidero abatible retráctil



ART.	A
4CA.445.000T . xx	600*
4CA.45Y.000T . xx	
4CA.45K.000T . xx	
4CA.445.0000 . xx	700*
4CA.45Y.0000 . xx	
4CA.45K.0000 . xx	
4CA.445.000L . xx	850*
4CA.45Y.000L . xx	
4CA.45K.000L . xx	

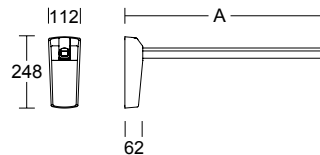

- Sostegno di sicurezza ribaltabile
- Lift-up safety support with friction device and armrest
- Barre d'appui relevable
- Opklapbare veiligheidssteun
- Asidero abatible



**POWDER COATED ALUMINIUM**

.XX STANDARD FINISH	.30	.24

Colori a richiesta: lotti minimi da concordare - Colours on demand: minimum lot to be agreed  
 Couleurs sur demande: lots minimum à convenir - Weitere Farben: auf Anfrage, mengenabhängig  
 Colores requeridos: lotes mínimos a convenir



◆ RIGHT

ART.	◆	A	B
CAP.422.0000 .xx .x		220 (252)*	520 (552)*
CAP.22J.0000 .xx .x			
CAP.422.000M .xx .x		300 (332)*	520 (552)*
CAP.22J.000M .xx .x			
CAP.422.000L .xx .x		320 (352)*	720 (752)*
CAP.22J.000L .xx .x			
CAP.422.00LA .xx .x		400 (432)*	1160 (1192)*
CAP.22J.00LA .xx .x			
CAP.422.9999 .xx .x	Ⓢ		
CAP.22J.9999 .xx .x			

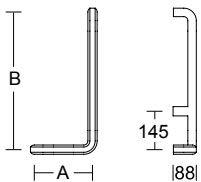

- ◆
- . 1 DESTRO RIGHT DROITE RECHTS DERECHA
- . 2 SINISTRO LEFT GAUCHE LINKS IZQUIERDA

- Sostegno di sicurezza a L
- L-shaped safety support
- Barre d'appui forme à L
- Sicherheitsgriff, L - Form
- Asidero en forma de L



◆ LEFT

ART.	◆	A	B	C
CAP.424.0000 .xx .x		660 (676)*	660 (678)*	820 (852)*
CAP.24J.0000 .xx .x				
CAP.424.000L .xx .x		760 (776)*	400 (418)*	1160 (1192)*
CAP.24J.000L .xx .x				
CAP.424.00LA .xx .x		760 (776)*	760 (778)*	1160 (1192)*
CAP.24J.00LA .xx .x				
CAP.424.9999 .xx .x	Ⓢ			
CAP.24J.9999 .xx .x				

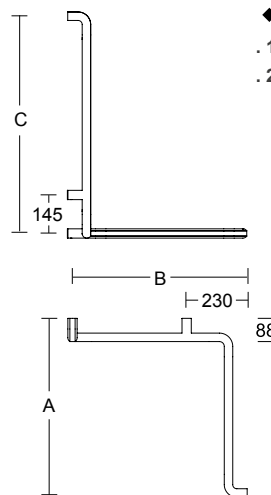

- ◆
- . 1 DESTRO RIGHT DROITE RECHTS DERECHA
- . 2 SINISTRO LEFT GAUCHE LINKS IZQUIERDA

- Sostegno di sicurezza ad angolo con impugnatura verticale
- Corner shower rail with shower head rail
- Barre d'appui à coin avec barre de douche
- Duschhandlauf mit Brausehalterstange
- Asidero para ducha con barra vertical



POWDER COATED ALUMINIUM

.XX STANDARD FINISH	.30	.24

Colori a richiesta: lotti minimi da concordare - Colours on demand: minimum lot to be agreed  
 Couleurs sur demande: lots minimum à convenir - Weitere Farben: auf Anfrage, mengenabhängig  
 Colores requeridos: lotes minimos a convenir





ART.	A
CAP.487.0000 .xx	570 (600)*
CAP.487.000A .xx	770 (800)*
CAP.487.000B .xx	970 (1000)*
CAP.487.000C .xx	1170 (1200)*
CAP.487.9999 .xx	

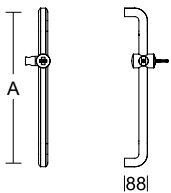

- Sostegno di sicurezza con reggisoffione
- Fixed safety support with shower head holder
- Barre d'appui fixe avec curseur de douchette
- Brausehalterstange mit Brausehalter
- Asidero con soporte para ducha



ART.	A
CAP.440.0000 .xx	370 (400)*
CAP.440.000A .xx	570 (600)*
CAP.440.000B .xx	770 (800)*
CAP.440.000C .xx	970 (1000)*
CAP.440.000Z .xx	300 (330)*
CAP.440.9999 .xx	

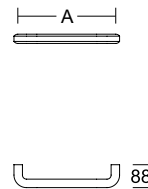

- Sostegno di sicurezza orizzontale
- Horizontal safety support
- Barre d'appui horizontale
- Haltegriff
- Asidero horizontal



**POWDER COATED ALUMINIUM**

.XX STANDARD FINISH	.30	.24

Colori a richiesta: lotti minimi da concordare - Colours on demand: minimum lot to be agreed  
 Couleurs sur demande: lots minimum à convenir - Weitere Farben: auf Anfrage, mengenabhängig  
 Colores requeridos: lotes minimos a convenir



ART.	A	B
CAP.490.0000 .xx	600*	1100*

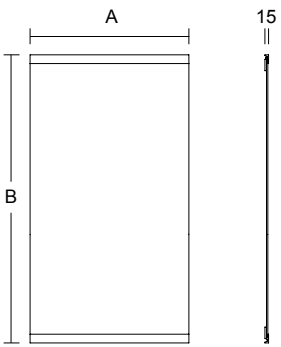

- Specchio fisso
- Fixed mirror
- Miroir fixe
- Spiegeleinheit
- Espejo fijo

**POWDER COATED ALUMINIUM**

.XX STANDARD FINISH	.30	.24



ART.	A	B	C
CAP.009.0000.30	260	260	325

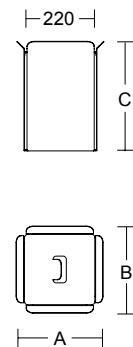

- Cestino
- Paper basket
- Poubelle
- Abfallbehälter
- Cubo de basura



ART.	A	B	C
CAP.483.0IBM. xx	150*	110*	130*

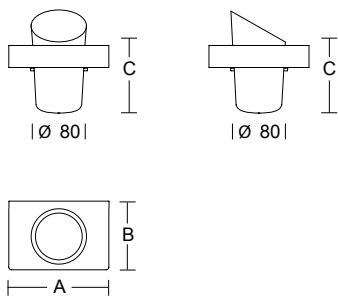

- Mensola con bicchiere in nylon
- Shelf with nylon tumbler
- Tablette avec gobelet en nylon
- Tablethouder met bekerhouder in nylon
- Estante con vaso de nylon



ART.	A	B	C
CAP.481.00BA . xx	150*	110	108

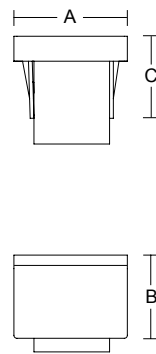

- Portarotolo a muro
- Wall toilet roll holder
- Porte-papier murale
- Papierrollenhalter
- Portarollo a pared

**POWDER COATED ALUMINIUM**

.XX STANDARD FINISH

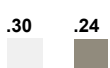





ART.	A	B	C
CAP.486.0000 .xx	150*	110*	380*

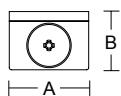
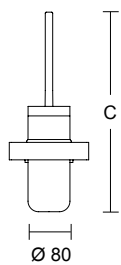

- Portascopino in nylon con mensola in alluminio
- Nylon toilet brush set with aluminium bathroom shelf
- Ensemble brosse WC en nylon avec tablette en aluminium
- Toilettenbürstengarnitur aus Nylon mit Halterung aus Aluminium
- Escobillero en nylon y soporte en aluminio

**POWDER COATED ALUMINIUM**

.XX STANDARD FINISH

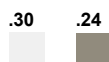

ART.	A	B
CAP.010.0000.30	193	752

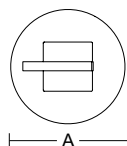
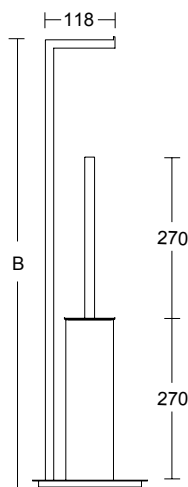

- Piantana portarotolo e porta scopino
- Toilet paper and brush holder stand
- Support pour porte-papier et ensemble brosse WC
- Stand WC-Papier und Bürstenhalter
- Base portarrotolo con escobillero





ART.	A	B
CAP.562.0000 .xx	Ø 50	76*

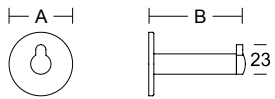

- Appendiabiti fermaporta
- Door-stop cloth hook
- Patère-butoir
- Wandhaken mit Türpufferelement
- Percha con tope de puerta

**POWDER COATED ALUMINIUM**

.XX STANDARD FINISH	.30	.24

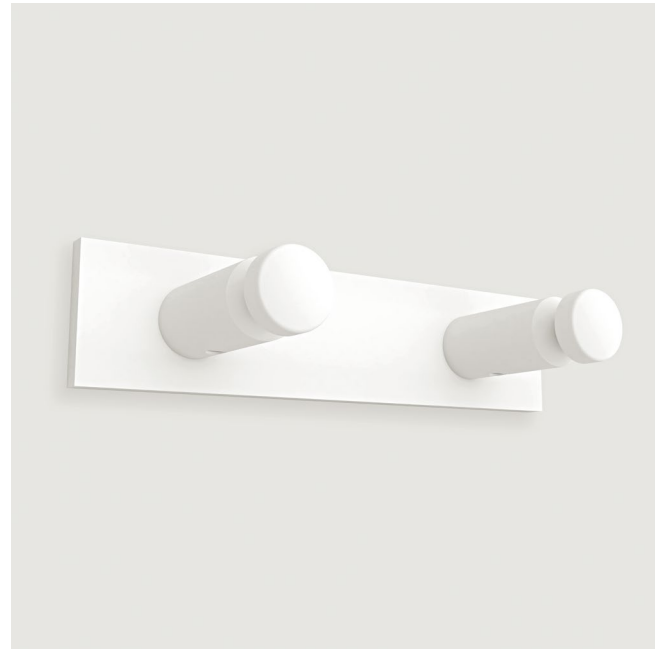

ART.	A	B
CAP.488.0000 .xx	125*	30*

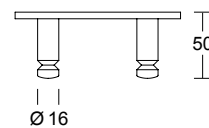
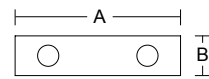

- Gancio appendiabiti doppio
- Double cloth hook
- Patère double
- Doppelwandhaken
- Percha doble



DESIGN FOR ALL È UNA COLLEZIONE DI ACCESSORI BAGNO ESPRESSIONE DELLA MATERIA E DELLA FORMA ALLO STATO PURO. TUTTI I PRODOTTI SONO REALIZZATI IN ACCIAIO INOSSIDABILE AISI 316L ATTRAVERSO UN'ATTENTA RICERCA DI FORME ESSENZIALI E DETTAGLI RAFFINATI PENSATI PER RIDURRE I VOLUMI E GARANTIRE LA MASSIMA FUNZIONALITÀ D'USO. L'ASSENZA DI GIUNZIONI E CERNIERE A VISTA ALLEGGERISCONO L'IMPATTO ESTETICO DEGLI OGGETTI, CONTRIBUENDO A RENDERE ELEGANTE E MODERNO L'AMBIENTE BAGNO.

DESIGN FOR ALL BATHROOM ACCESSORIES COLLECTION IS AN EXPRESSION OF MATERIALITY AND FORM AT ITS PUREST. CRAFTED BY HAND OF AISI 316L STAINLESS STEEL MAXIMUM ATTENTION WAS GIVEN TO CREATING MINIMAL SHAPES WITH REFINED DETAILS ... ALL TO REDUCE VISUAL CLUTTER AND TO DELIVER AN ELEVATED END USER FRIENDLY EXPERIENCE. FROM THE ABSENCE OF FLANGES AND EXPOSED HINGES TO A TRADEMARK REVEAL THAT IMPARTS A DISCERNIBLE LIGHTNESS, EVERY ITEM IN THE RANGE BRINGS AN INCOMPARABLE ELEGANCE AND SENSE OF MODERNITY TO THE RESTROOM ENVIRONMENT.

DESIGN FOR ALL EST UNE COLLECTION DES ACCESSOIRES POUR SALLES DE BAIN ET EST L'EXPRESSION DE LA MATIÈRE ET SA FORME DANS SON ESSENCE. TOUS LES ARTICLES DE CETTE COLLECTION ONT ÉTÉ FABRIQUÉS EN ACIER INOX AISI 316L, GRÂCE À UNE RECHERCHE ATTENTIVE AUX FORMES ESSENTIELLES ET DÉTAILS RAFFINÉS CONÇUS POUR RÉDUIRE LES VOLUMES ET GARANTIR UNE FONCTIONNALITÉ MAXIMALE DANS L'USAGE QUOTIDIEN. L'IMPACT VISUEL DEVIENT MINIMALISTE POUR LE MANQUE DE JONCTIONS ET CONTRIBUANT À DONNER UN ASPECT ÉLÉGANT ET MODERNE À LA SALLE DE BAIN.

DESIGN FOR ALL BADACCESSOIRES-KOLLEKTION IST AUSDRUCK PURER MATERIE UND FORM. ALLE PRODUKTE DER KOLLEKTION WERDEN AUS EDELSTAHL AISI 316L HERGESTELLT, DURCH EINE SORGFÄLTIGE SUCHE NACH WESENTLICHEN FORMEN UND RAFFINIERTEN DETAILS, DIE DARAUFGESICHTET SIND, DAS VOLUMEN ZU REDUZIEREN UND MAXIMALE FUNKTIONALITÄT ZU GEWÄHRLEISTEN. DAS FEHLEN VON SICHTBAREN FUGEN UND SCHARNIEREN ERLEICHTERT DIE ÄSTHETISCHE WIRKUNG DER OBJEKTE, WAS DAZU BEITRÄGT, DIE BADEZIMMERUMGEBUNG ELEGANT UND MODERN ZU GESTALTEN.

DESIGN FOR ALL ES LA COLECCIÓN ACCESORIOS DE BAÑO EXPRESIÓN DE LA MATERIA Y DE LA FORMA EN SU ESTADO PURO. TODOS LOS PRODUCTOS SON DE ACERO INOXIDABLE AISI 316L, A TRAVÉS DE UNA BÚSQUEDA CUIDADA DE FORMAS ESSENCIALES Y DETALLES REFINADOS PENSADOS PARA REDUCIR LOS TAMAÑOS Y GARANTIZAR AL USUARIO LA MÁXIMA FUNCIONALIDAD. LA AUSENCIA DE JUNTOS Y BISAGRAS VISIBLES DAN A LOS OBJETOS UN IMPACTO ESTÉTICO MÍNIMO, CONTRIBUYENDO A HACER EL AMBIENTE DEL BAÑO ELEGANTE Y MODERNO.



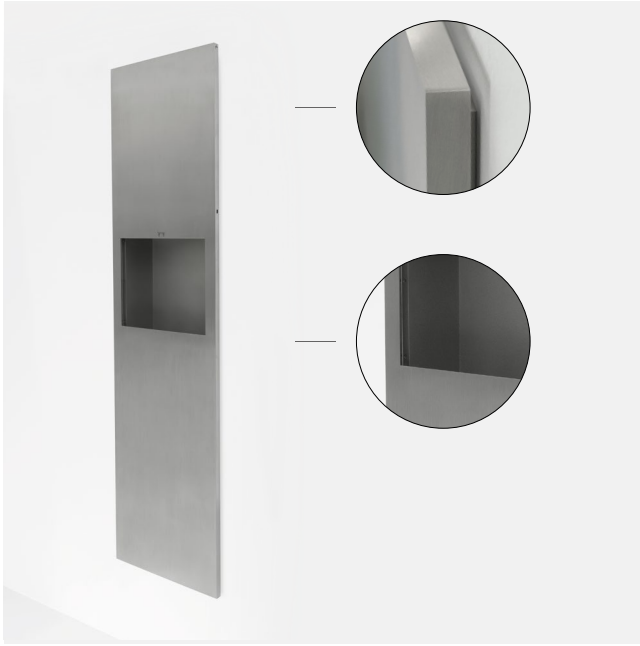

ART.  
GBA.101.0000. xx

□ Outer surface  
■ Inner surface

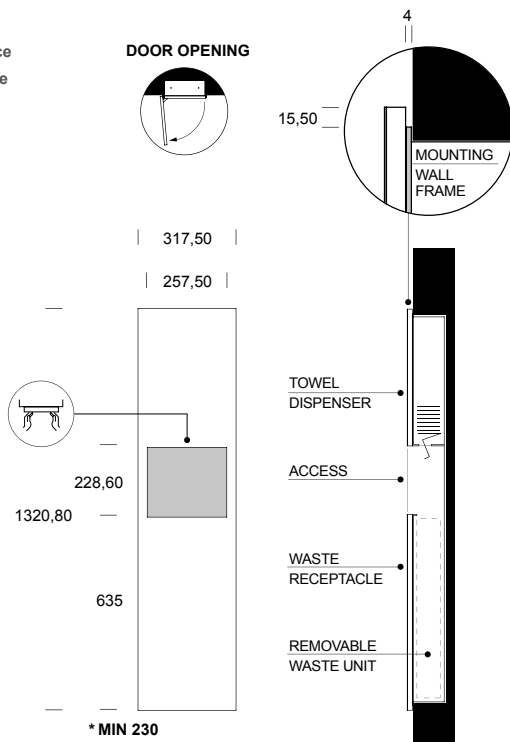

- Dispenser di salviette con cestino piccolo ad incasso
- Combination paper towel dispenser / waste unit small - recessed
- Combinaison distributeur de serviettes avec une petite poubelle à encastrer
- Kombination Papierhandtuchspender/Abfallbehälter Eibauwandmontage
- Dispensador de toallas con papelera pequeña empotrada

STAINLESS STEEL AISI 316L .XX STANDARD FINISH

SATIN	POWDER COATED				
.44	.31	.38	.39	.32	.40



ART.  
GBA.105.0001. xx + GBA.105.0003. xx

□ Outer surface  
■ Inner surface

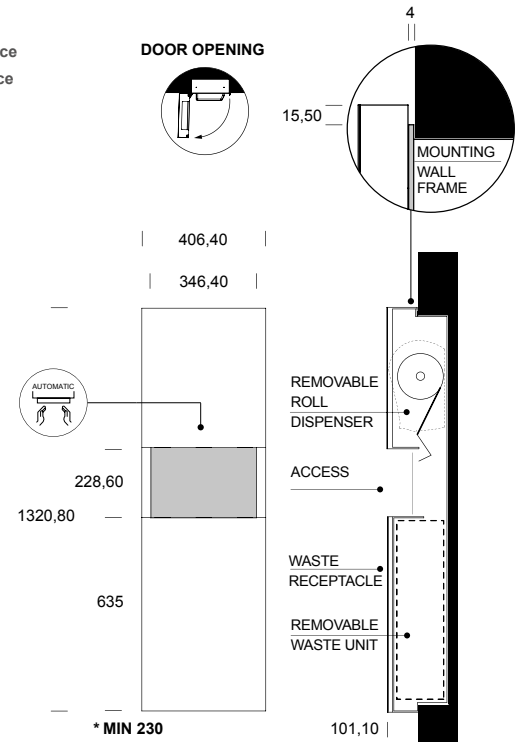

- Dispenser di carta con cestino grande ad incasso
- Combination paper towel dispenser / waste unit big - recessed
- Combinaison distributeur de serviettes avec une grande poubelle à encastrer
- Abfalleinheit zur umwandelbaren Kombi - Eibauwandmontage
- Dispensador de papel combinado con papelera grande empotrada





ART.  
GBA.103.0000. xx

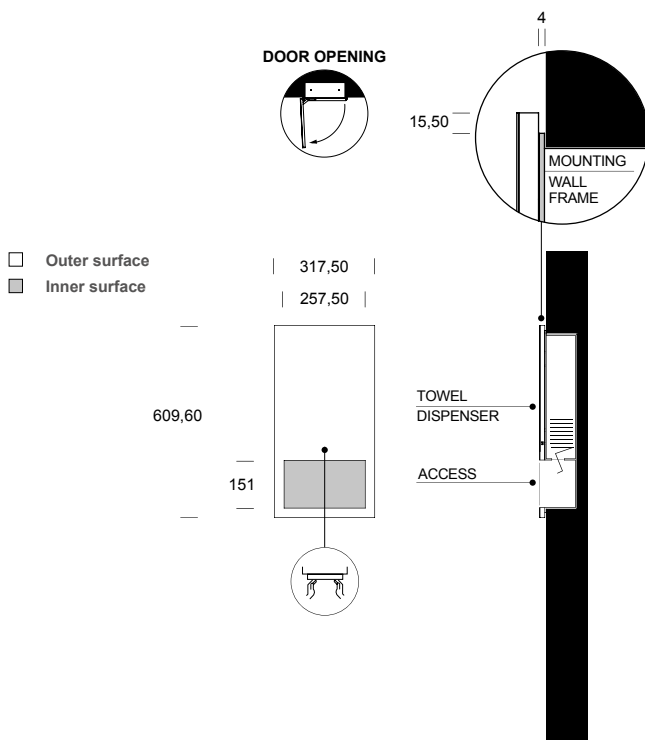

- Dispenser di salviette ad incasso
- Paper Towel Dispenser - recessed
- Distributeur de serviettes à encastrer
- Papierhandtuchspender - Eibauwandmontage
- Dispensador de toallas empotrado

STAINLESS STEEL AISI 316L .XX STANDARD FINISH

SATIN	POWDER COATED				
.44	.31	.38	.39	.32	.40



ART.  
GBA.104.0000. xx

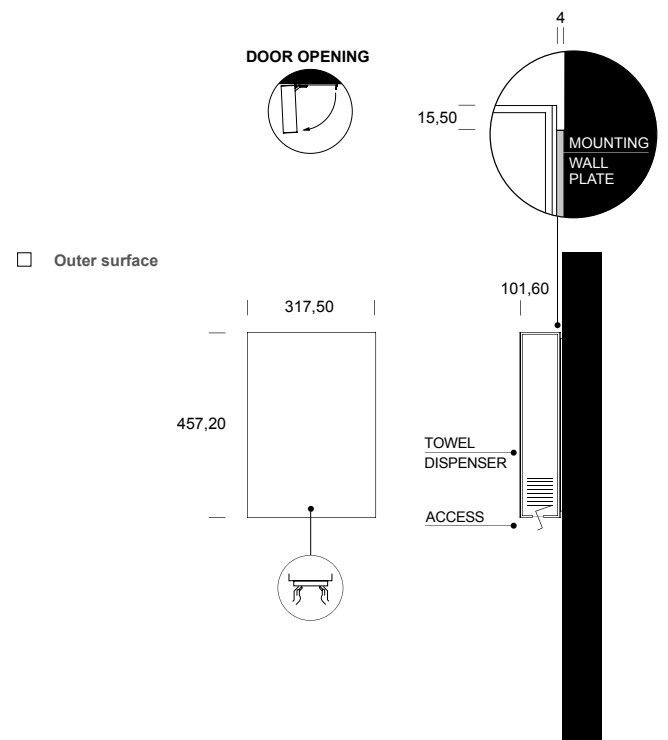

- Dispenser di salviette a muro
- Paper towel dispenser - surface mounted
- Distributeur de serviettes - installation au mur
- Papierhandtuchspender - Aufputzwandmontage
- Dispensador de toallas para pared



ART.  
GBA.107.0000. xx

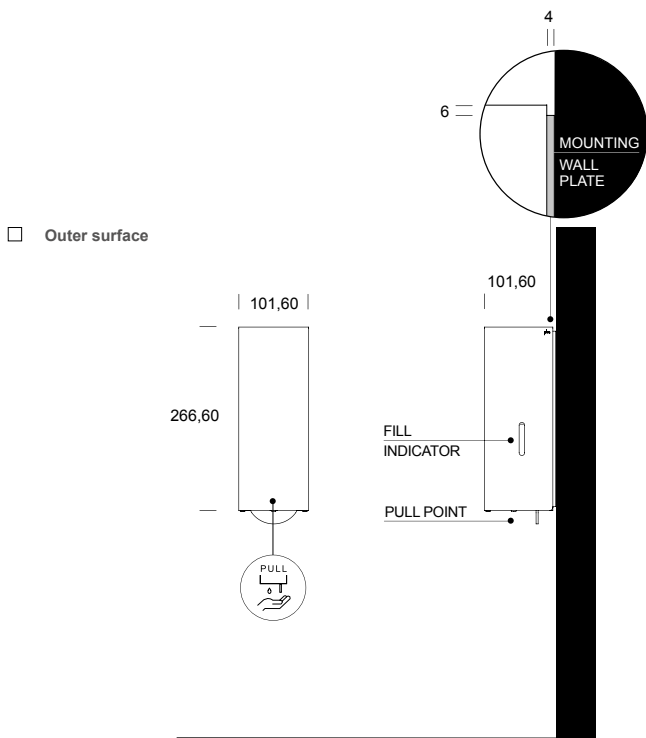

- Dispenser di sapone con erogazione manuale
- Soap dispenser - manually operated - surface mounted
- Distributeur de savon manuel - installation au mur
- Seifenspender-Abdeckung - Aufputzwandmontage
- Dispensador de jabón con dosificación manual para pared

STAINLESS STEEL AISI 316L .XX STANDARD FINISH

SATIN	POWDER COATED				
.44	.31	.38	.39	.32	.40



ART.  
GBA.108.0001. xx

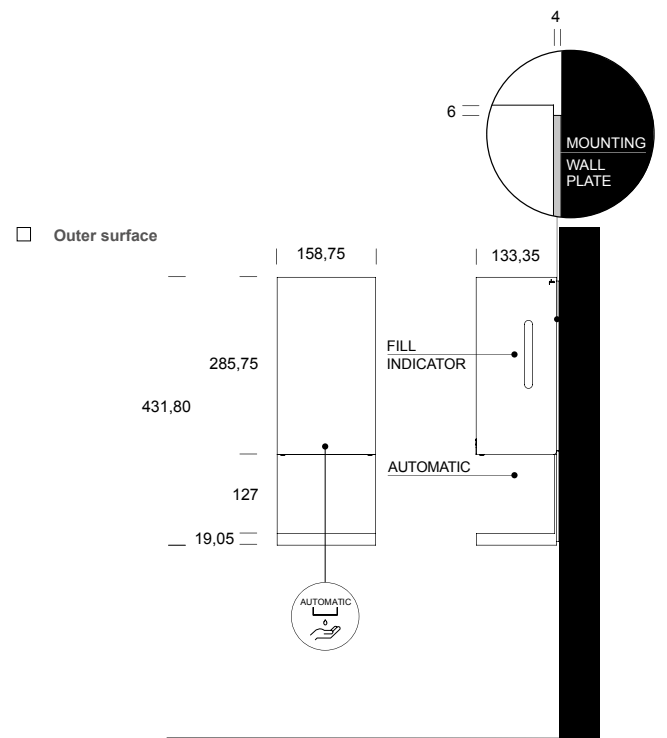

- Dispenser di sapone con erogazione automatica e salvagocia
- Automatic soap dispenser with drip tray - surface mounted
- Distributeur automatique de savon avec bac anti-gouttes - installation au mur
- Seifenspender-Abdeckung mit Ablage - Aufputzwandmontage
- Dispensador de jabón con recogegotas dosificación automática para pared



ART.  
GBA.117.0000. xx

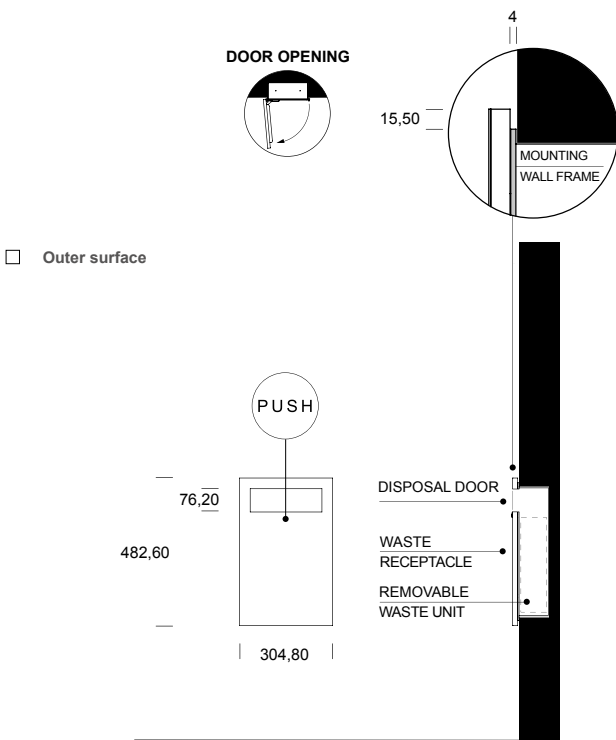

- Cestino ad incasso per tamponi e assorbenti
- Sanitary napkin / tampon waste unit - recessed
- Poubelle pour serviettes hygiéniques à encastrer
- Damenbinden-/Tampon-Abfalleinheit - Eibauwandmontage
- Papelera para tampones empotrado

STAINLESS STEEL AISI 316L .XX STANDARD FINISH

SATIN	POWDER COATED				
.44	.31	.38	.39	.32	.40



ART.  
GBA.119.0000. xx

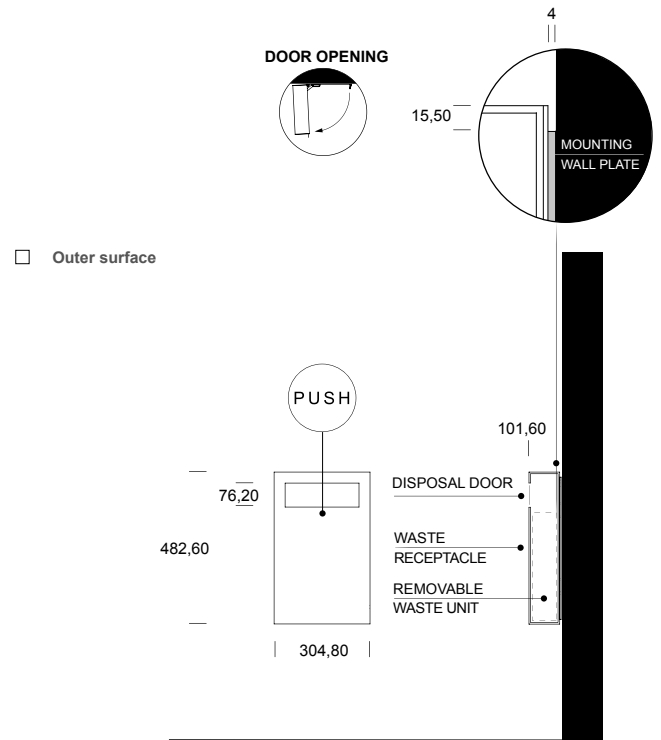

- Cestino a muro per tamponi e assorbenti
- Sanitary napkin / tampon waste unit - surface mounted
- Poubelle pour serviettes hygiéniques - installation au mur
- Damenbinden-/Tampon-Abfalleinheit - Aufputzwandmontage
- Papelera para tampones para pared





ART.  
GBA.111.0000. xx

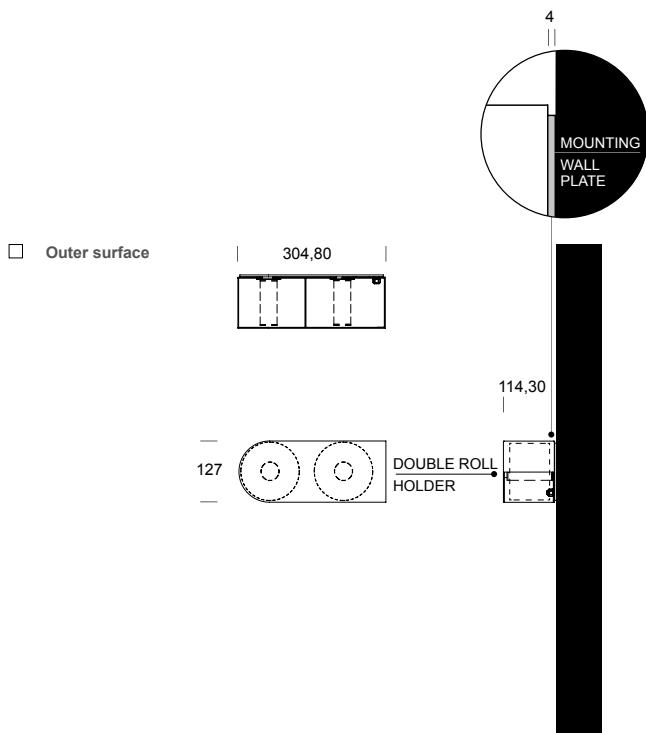

- Portarotolo doppio con copertura
- Toilet tissue dispenser double small roll covered
- Double porte rouleau de papier toilet - installation au mur
- Papierrollenhalter für 2 Rollen - Aufputzwandmontage
- Portarrollos doble cerrado para pared

STAINLESS STEEL AISI 316L .XX STANDARD FINISH

SATIN	POWDER COATED				
.44	.31	.38	.39	.32	.40



ART.  
GBA.113.0000. xx

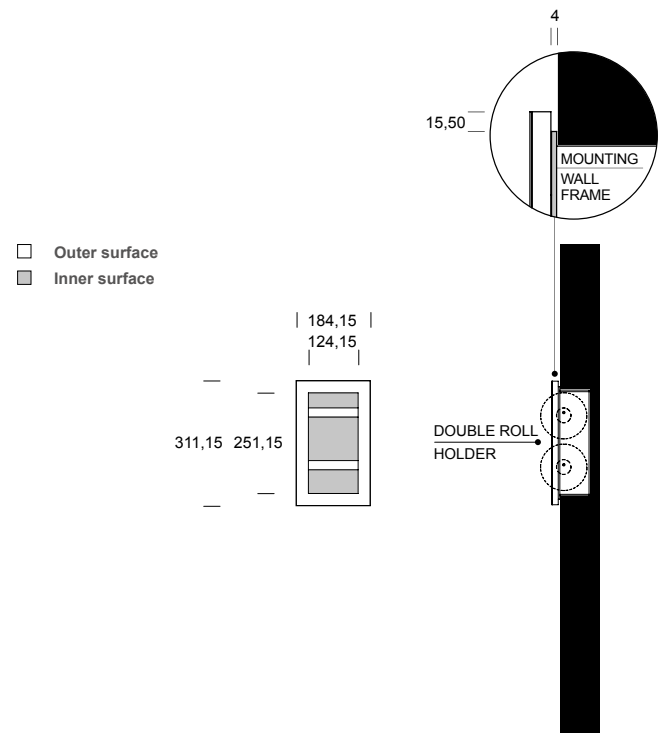

- Portarotolo doppio ad incasso
- Toilet tissue dispenser double small roll - recessed
- Double porte rouleau de papier toilet à encastrer
- Papierrollenhalter für 2 Rollen - Eibauwandmontage
- Portarrollos doble empotrado



ART.  
GBA.109.0000. xx

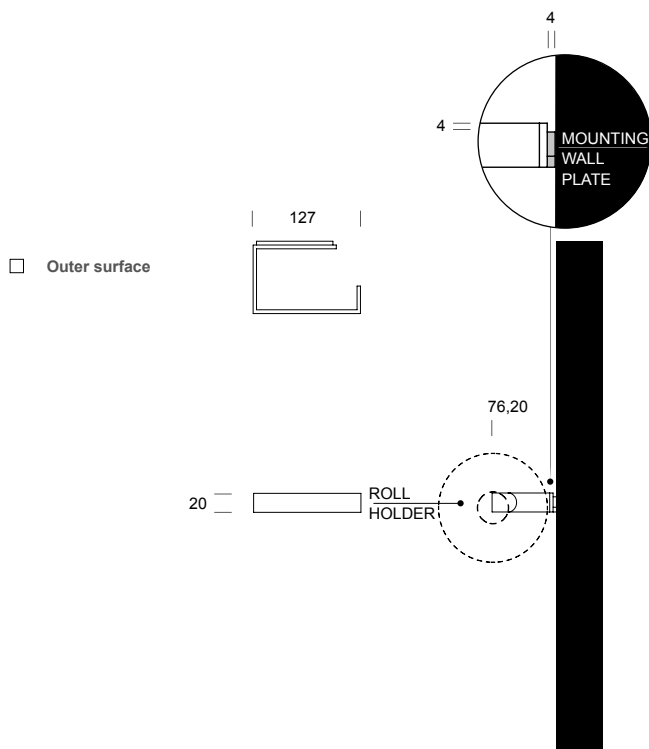

- Portarotolo
- Toilet tissue dispenser single small roll flat. Surface mounted
- Porte rouleau de papier toilet - installation au mur
- Papierrollenhalter gestreckt für 1 Rolle - Aufputzwandmontage
- Portarollo para pared

STAINLESS STEEL AISI 316L .XX STANDARD FINISH

SATIN	POWDER COATED				
.44	.31	.38	.39	.32	.40



ART.                      A  
GBA.120.0001. xx      304,80 mm  
GBA.120.0002. xx      457,20 mm  
GBA.120.0003. xx      609,60 mm

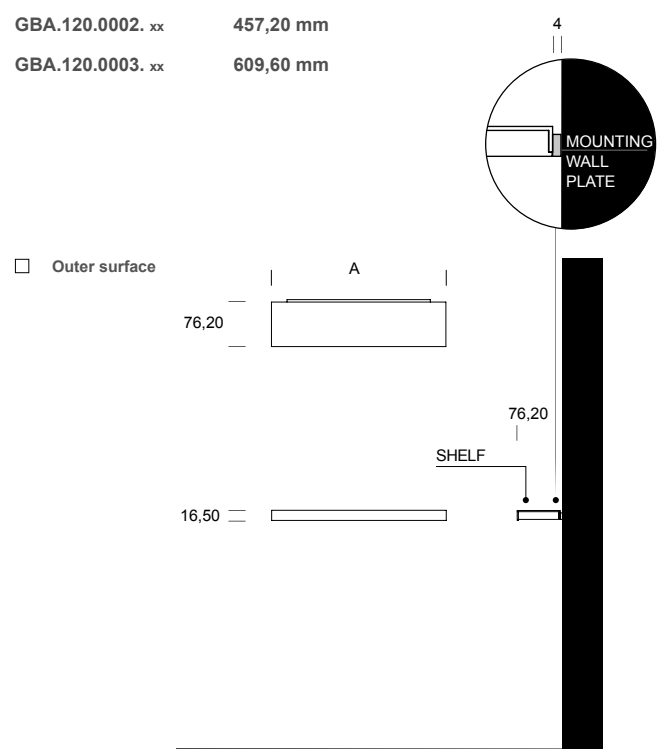

- Mensola
- Shelf - surface mounted 3" projection
- Tablette - installation au mur
- Ablage - Aufputzwandmontage
- Estante para pared

TELAJ E PROTEZIONI PER SEGGIOLINO E SOSTEGNO DI SICUREZZA

FIXTURES AND PROTECTIONS FOR SHOWER SEAT AND SAFETY SUPPORT

BÂTIS ET PROTECTION POUR SIÈGE ET BARRE D'APPUI

UNTERKONSTRUKTIONEN UND WANDEINBAUSCHALEN FÜR DUSCHSITZ UND STÜTZKLAPPGRIFF

BASTIDORES Y PROTECCIONES PARA ASIENTO Y ASIDERO ABATIBLE

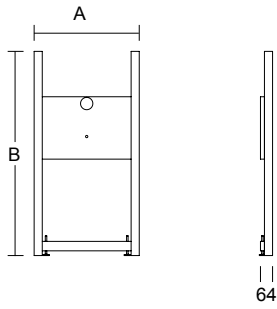

ART.	A	B
CAP.447.CG0B.00	556	1080

- Telaio per applicare art. CAP.447.000B nelle pareti in cartongesso
- Fixture on plasterboard walls for the application of article CAP.447.000B
- Bâti à introduire dans les parois en placoplâtre pour l'application de l'article CAP.447.000B
- Unterkonstruktion zum Einbau in Leichtbauwänden für Art. CAP.447.000B
- Bastidor que se inserta en los paneles de yeso para aplicar el artículo CAP.447.000B

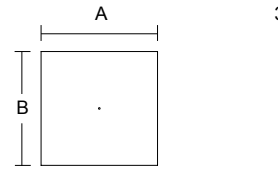

ART.	A	B
CAP.447.DM0B.00	440	430

- Dima per foro di alloggiamento art. CAP.447.000B nelle pareti in cartongesso
- Drill template for art. CAP.447.000B for plasterboard walls
- Gabarit pour trous de fixation de l'article CAP.447.000B pour parois en placoplâtre
- Schablone zum Einbau in Leichtbauwänden für Art. CAP.447.000B
- Plantilla para agujeros de alojamiento del art. CAP.447.000B en paneles de yeso

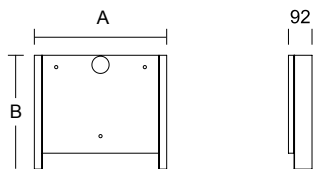

ART.	A	B
CAP.447.MR0B.00	500	430

- Telaio per applicare art. CAP.447.000B nelle pareti in muratura
- Fixture to set in brick walls for the application of article CAP.447.000B
- Bâti à introduire dans les maçonneries pour l'application de l'article CAP.447.000B
- Wandeinbauschale für massive Wände für Art. CAP.447.000B
- Bastidor que se empotra en las paredes de mampostería para aplicar el artículo CAP.447.000B

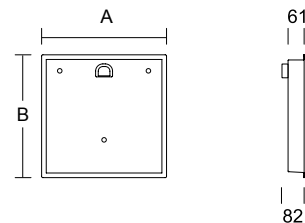

ART.	A	B
CAP.447.WP0B.00	472	465

- Protezione a tenuta stagna per art. CAP.447.000B
- Watertight protection for art. CAP.447.000B
- Protection étanche pour l' article CAP.447.000B
- Feuchtigkeitsschutz für Trockenbau und Massivbau für Art. CAP.447.000B
- Protección estanca para art CAP.447.000B

SISTEMI DI FISSAGGIO - FIXING MATERIAL - INFORMATIONS TECHNIQUES - TECHNISCHE INFORMATIONEN - INFORMACIONES TÉCNICAS

ART. CAP.447.000B

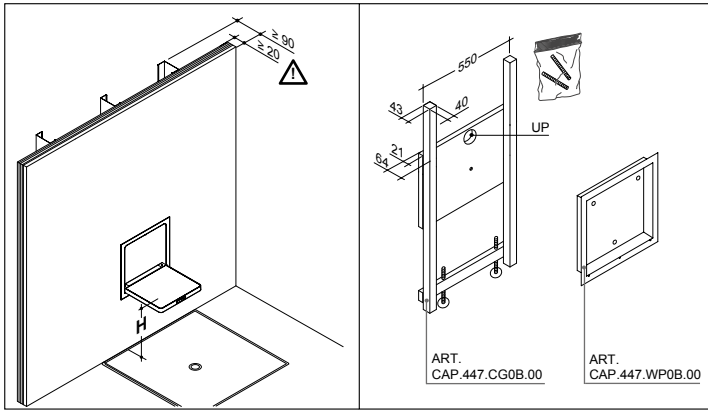

CARTONGESSO - PLASTERBOARD - PLACOPLÂTRE - GIPSKARTONWÄNDEN  
 PANEL DE YESO - PLACA DE GESSO

- (D)** DIN 18040-1, DIN 18040-2 H= 480 H1= 840
- (I)** DM 236 14/06/1989 H= 480 H1= 840
- (GB)** APPROVED DOCUMENT M H= 480 H1= 840
- (A)** Ö - NORM B 1600 H= 480 H1= 840
- (F)** JORF n°195 (24/08/2006) H= 480 H1= 840  
 Text 14 AFNOR NF P 99-611

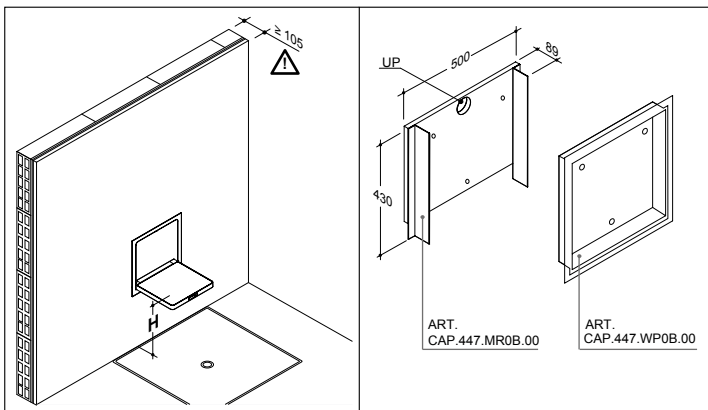
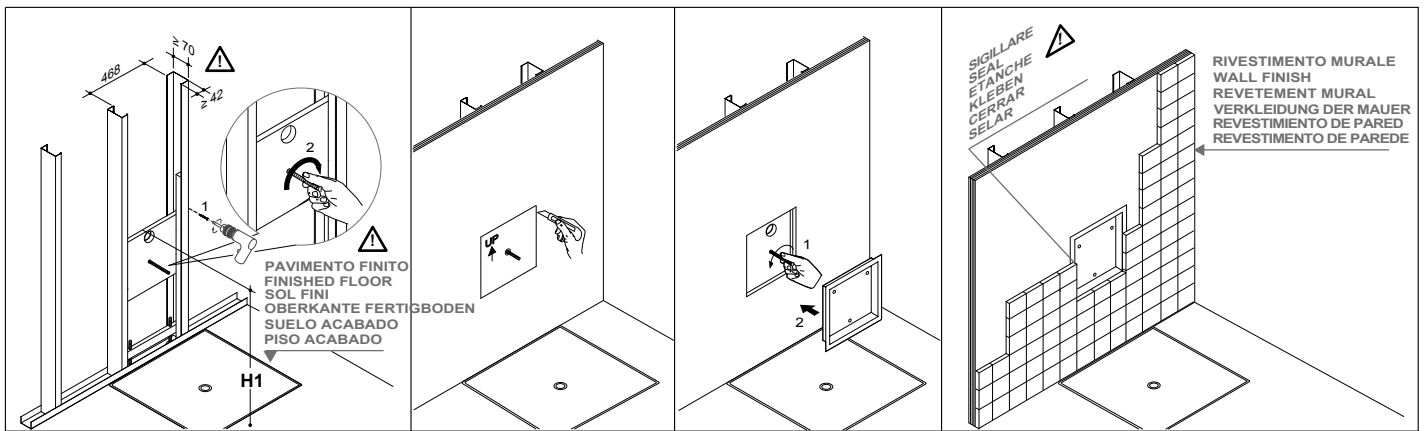

MURATURA - BRICK WALLS - MAÇONNEES - MASSIVWÄNDEN -  
 MAMPOSTERÍA - ALVENARIA

- (D)** DIN 18040-1, DIN 18040-2 H= 480 H1= 415
- (I)** DM 236 14/06/1989 H= 480 H1= 415
- (GB)** APPROVED DOCUMENT M H= 480 H1= 415
- (A)** Ö - NORM B 1600 H= 480 H1= 415
- (F)** JORF n°195 (24/08/2006) H= 480 H1= 415  
 Text 14 AFNOR NF P 99-611

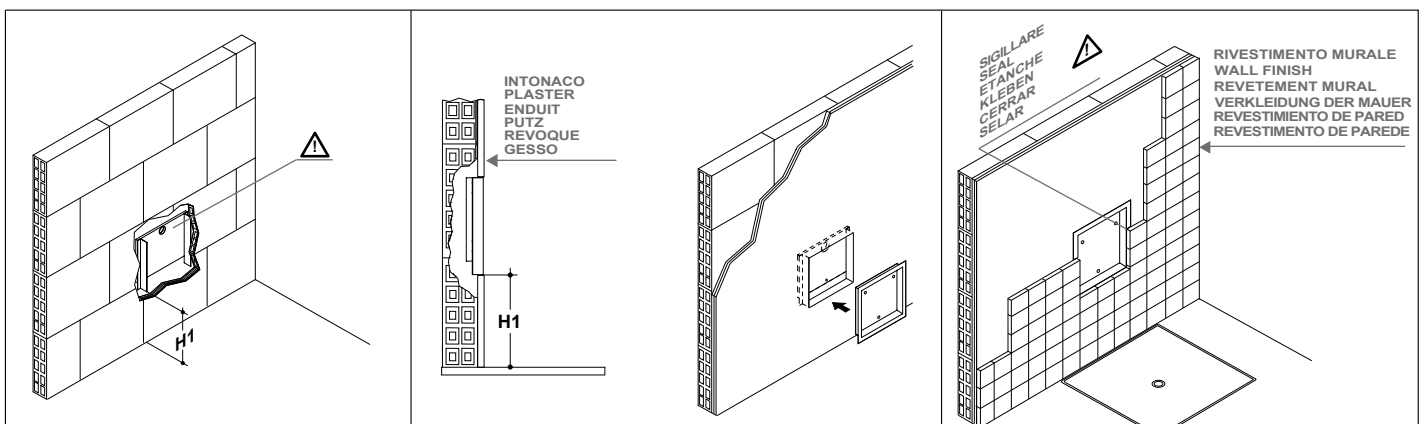

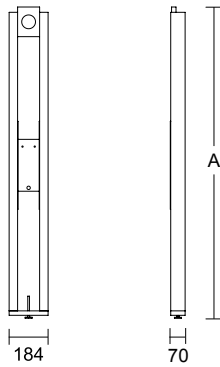

ART.	A	
CAP.445.CG01.00	1470	(I) (F)
CAP.445.CG02.00	1350	(GB)
CAP.445.CG03.00	1410	(D) (A)

- Telaio per applicare art. CAP.445.000T, CAP.445.0000 nelle pareti in cartongesso
- Fixture on plasterboard walls for the application of articles CAP.445.000T, CAP.445.0000
- Bâti à introduire dans les parois en placoplâtre pour l'application des articles CAP.445.000T et CAP.445.0000
- Unterkonstruktion zum Einbau in Leichtbauwänden für Art. CAP.445.000T, CAP.445.0000
- Bastidor que se inserta en los paneles de yeso para aplicar los artículos CAP.445.000T, CAP.445.0000

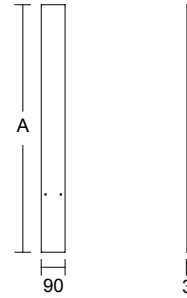

ART.	A
CAP.445.DM0T.00	835
CAP.445.DM00.00	935

- Dima per fori di alloggiamento art. CAP.445.000T (CAP.445.DM0T.00), CAP.445.0000 (CAP.445.DM00.00) nelle pareti in cartongesso
- Drill template for art. CAP.445.000T (CAP.445.DM0T.00) and CAP.445.0000 (CAP.445.DM00.00) for plasterboard walls
- Gabarit pour trous de fixation des articles CAP.445.000T (CAP.445.DM0T.00) et CAP.445.0000 (CAP.445.DM00.00) pour parois en placoplâtre
- Schablone zum Einbau in Leichtbauwänden für Art. CAP.445.000T (CAP.445.DM0T.00), CAP.445.0000 (CAP.445.DM00.00)
- Plantilla para agujeros de alojamiento del art. CAP.445.000T (CAP.445.DM0T.00) y CAP.445.0000 (CAP.445.DM00.00) en paneles de yeso

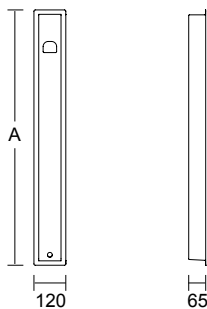

ART.	A
CAP.445.WP0T.00	865
CAP.445.WP00.00	965

- Protezione a tenuta stagna per art. CAP.445.000T (CAP.445.WP0T.00), CAP.445.0000 (CAP.445.WP00.00)
- Watertight protection for art CAP.445.000T (CAP.445.WP0T.00), CAP.445.0000 (CAP.445.WP00.00)
- Protection étanche pour les articles CAP.445.000T (CAP.445.WP0T.00), CAP.445.0000 (CAP.445.WP00.00)
- Feuchtigkeitsschutz für Trockenbau und Massivbau für Art. CAP.445.000T (CAP.445.WP0T.00), CAP.445.0000 (CAP.445.WP00.00)
- Protección estanca para art CAP.445.000T (CAP.445.WP0T.00), CAP.445.0000 (CAP.445.WP00.00)

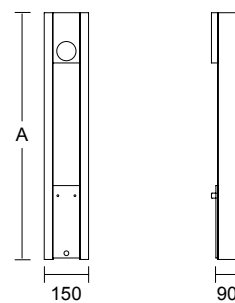

ART.	A
CAP.445.MR0T.00	835
CAP.445.MR00.00	935

- Telaio per applicare art. CAP.445.000T (CAP.445.MR0T.00), CAP.445.0000 (CAP.445.MR00.00) nelle pareti in muratura
- Fixture to set in brick walls for the application of articles CAP.445.000T (CAP.445.MR0T.00), CAP.445.0000 (CAP.445.MR00.00)
- Bâti à introduire dans les parois maçonnées pour l'application des articles CAP.445.000T (CAP.445.MR0T.00), CAP.445.0000 (CAP.445.MR00.00)
- Wandeinbauschaale für massive Wände für Art. CAP.445.000T (CAP.445.MR0T.00), CAP.445.0000 (CAP.445.MR00.00)
- Bastidor que se empotra en las paredes de mampostería para aplicar los artículos CAP.445.000T (CAP.445.MR0T.00), CAP.445.0000 (CAP.445.MR00.00)

SISTEMI DI FISSAGGIO - FIXING MATERIAL - INFORMATIONS TECHNIQUES - TECHNISCHE INFORMATIONEN - INFORMACIONES TÉCNICAS

ART. CAP.445.000T - CAP.445.0000

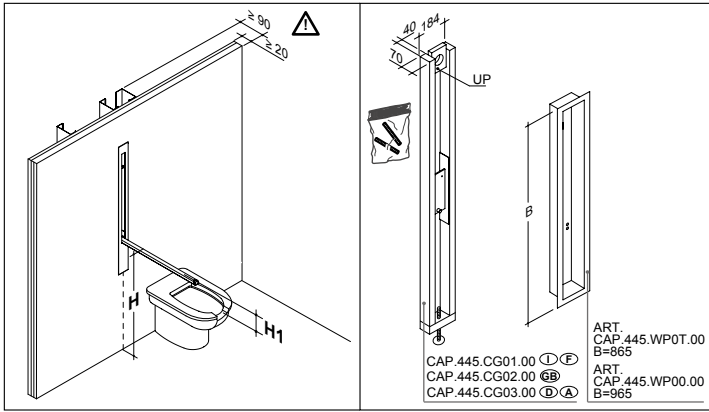

CARTONGESSO - PLASTERBOARD - PLACOPLÂTRE - GIPSKARTONWÄNDEN  
 PANEL DE YESO - PLACA DE GESSO

(D)	DIN 18040-1, DIN 18040-2	H= 740/760	H1= 280	H2= 785/805
(I)	DM 236 14/06/1989	H= 800	H1= -	H2= 845
(GB)	APPROVED DOCUMENT M	H= 680	H1= -	H2= 725
(A)	Ö - NORM B 1600	H= 750	H1= -	H2= 795
(F)	JORF n°195 (24/08/2006) Text 14 AFNOR NF P 99-611	H= 800	H1= -	H2= 845

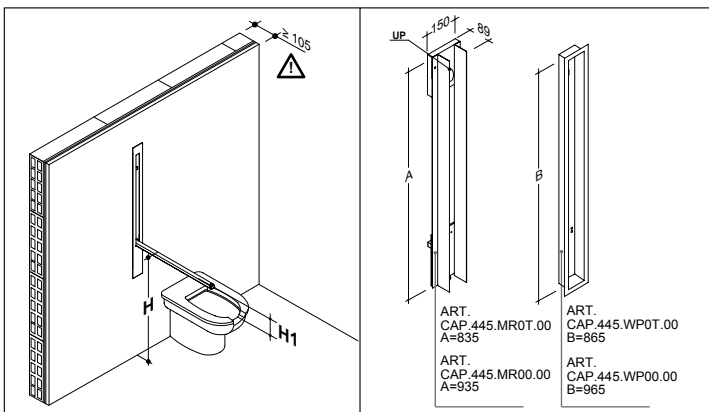
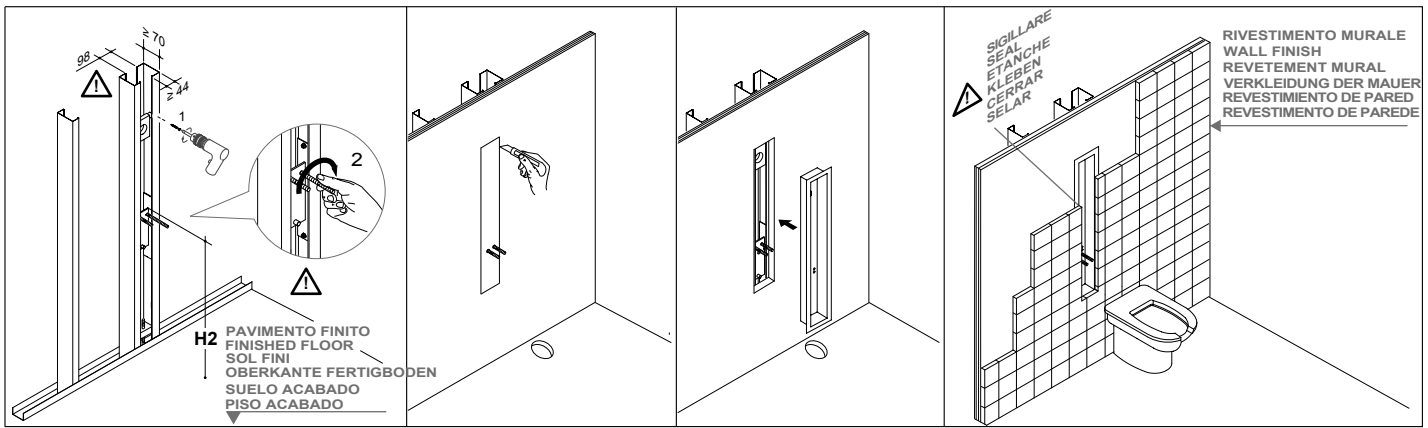

MURATURA - BRICK WALLS - MAÇONNEES - MASSIVWÄNDEN -  
 MAMPOSTERIA - ALVENARIA

(D)	DIN 18040-1, DIN 18040-2	H= 740/760	H1= 280	H2= 535/555
(I)	DM 236 14/06/1989	H= 800	H1= -	H2= 595
(GB)	APPROVED DOCUMENT M	H= 680	H1= -	H2= 475
(A)	Ö - NORM B 1600	H= 750	H1= -	H2= 545
(F)	JORF n°195 (24/08/2006) Text 14 AFNOR NF P 99-611	H= 800	H1= -	H2= 595

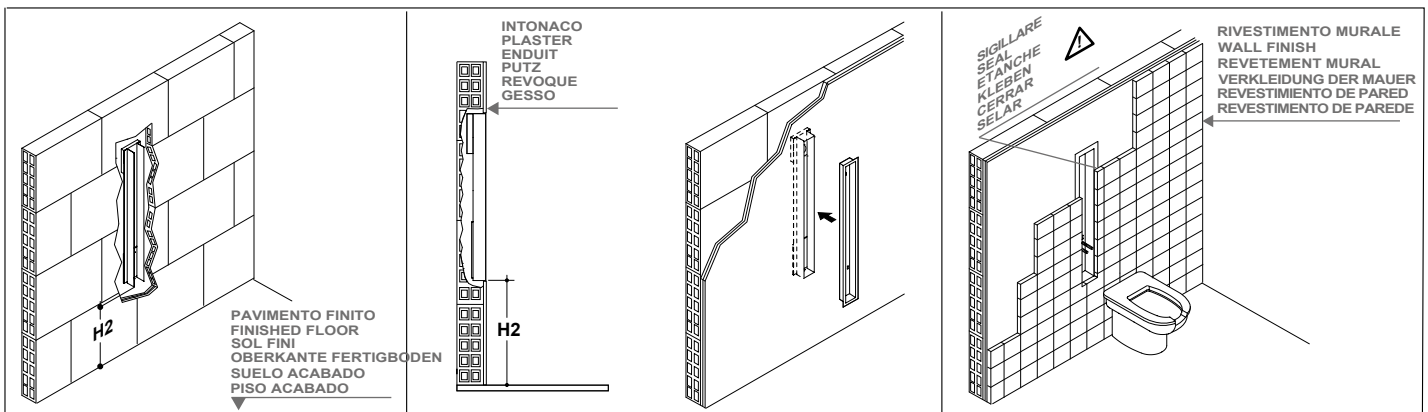

SISTEMI DI FISSAGGIO - FIXING MATERIAL - INFORMATIONS TECHNIQUES - TECHNISCHE INFORMATIONEN - INFORMACIONES TÉCNICAS

ART. 4CA.445.000T - 4CA.445.0000 - 4CA.445.000L

<p>Art. 4CA.445.000T.xx 4CA.45Y.000T.xx 4CA.45K.000T.xx 4CA.445.0000.xx 4CA.45Y.0000.xx 4CA.45K.0000.xx 4CA.445.000L.xx 4CA.45Y.000L.xx 4CA.45K.000L.xx</p>	<p>Calcestruzzo e Pietra naturale - Concrete, Natural stone - Béton et Pierre naturelle - Beton, Voll-Naturstein - Hormigón y piedra natural</p> <p><b>KIT 4CN.0VM.0014.00</b> In dotazione - Included - Inklus - Includido:</p> <ul style="list-style-type: none"> <li>N°3 Fischer FU 10x60</li> <li>N°3 6,3x80 INOX</li> <li>N°3 bussole guida guide bushes douilles de guidage casquillo guía</li> </ul>	<p>Mattone pieno e Mattone calcareo - Solid brick, Sand-lime brick -Brique pleine et brique calcaire - Vollziegel, Kalksandvollstein - Ladrillo macizo y sílico calcáreo</p> <p><b>KIT 4CN.0VM.0014.00</b> In dotazione - Included - Inklus - Includido:</p> <ul style="list-style-type: none"> <li>N°3 Fischer FU 10x60</li> <li>N°3 6,3x80 INOX</li> <li>N°3 bussole guida guide bushes douilles de guidage casquillo guía</li> </ul>
	<p>Mattone forato - Hollow brick masonry - Brique creuse - Lang / Hochlochziegel, Kalksandlochstein, Porenbeton - Ladrillo hueco</p> <p><b>KIT 4CN.0VM.0033.00</b> A pagamento - Extra - En supplément - De pago:</p> <ul style="list-style-type: none"> <li>N°3 Fischer FIS H 16X85 K</li> <li>N°3 M8x30 INOX</li> <li>N°3 FIS E 11X85 M8</li> </ul>	<p>Cartongesso e legno stratificato - Plasterboard, Wooden plate - Placoplâtre - Panneau de bois lamellé - Mehrschicht-Holzplatten - Panel de cartón yeso y madera laminada</p> <p><b>KIT 4CN.0VM.0034.00</b> A pagamento - Extra - En supplément - De pago:</p> <ul style="list-style-type: none"> <li>N°3 8x90 INOX</li> </ul>

AUSILI - DISABLED ACCESSORIES - BARRES DE MAINTIEN - SICHERHEITSGRIFFE - ASIDEROS

<p>Ausili Disabled accessories Barres de maintien Asideros</p>	<p>Calcestruzzo e Pietra naturale - Concrete, Natural stone - Béton et Pierre naturelle - Beton, Voll-Naturstein - Hormigón y piedra natural</p> <p><b>KIT CAP.0VM.MR01.00</b> In dotazione - Included - Inklus - Includido:</p>	<p>Mattone pieno e Mattone calcareo - Solid brick, Sand-lime brick -Brique pleine et brique calcaire - Vollziegel, Kalksandvollstein - Ladrillo macizo y sílico calcáreo</p> <p><b>KIT CAP.0VM.MR01.00</b> In dotazione - Included - Inklus - Includido:</p>
	<p>Cartongesso e legno stratificato - Plasterboard, Wooden plate - Placoplâtre - Panneau de bois lamellé - Mehrschicht-Holzplatten - Panel de cartón yeso y madera laminada</p> <p><b>KIT CAP.0VM.CG01.00</b> In dotazione - Included - Inklus - Includido:</p>	

**NOTA:** PER FISSAGGI SU ALTRI MATERIALI E PER LO SPESSORE MINIMO DEL LEGNO DA UTILIZZARE COME RINFORZO DEL CARTONGESSO, RIVOLGERSI ALL'UFFICIO TECNICO pba.  
**NOTE:** FOR FIXING ON OTHER MATERIALS AND FOR THE MINIMUM THICKNESS OF THE WOOD REINFORCEMENT FOR PLASTERBOARD, PLEASE CONTACT pba TECHNICAL DEPT.  
**REMARQUE:** POUR FIXATION SUR D'AUTRES MATÉRIAUX ET POUR L'ÉPAISSEUR MINIMUM DU BOIS À UTILISER COMME RENFORCEMENT DANS LE PLACOPLÂTRE, CONTACTEZ LE SERVICE TECHNIQUE pba.  
**NOTA:** PARA FIJAR EN OTROS MATERIALES Y PARA EL ESPESOR MÍNIMO DE LA MADERA QUE HAY QUE UTILIZAR COMO REFUERZO DEL PANEL DE CARTÓN YESO, CONTACTEN EL DEPARTAMENTO TÉCNICO pba.  
**HINWEIS:** BEZÜGLICH WEITERER BEFESTIGUNGSARTEN UND FÜR DIE MINDESTDICKE DES HOLZES, DAS ALS VERSTÄRKUNG AUF GIPSKARTON ZU VERWENDEN IST, WENDEN SIE SICH BITTE AN UNSERE TECHNISCHE ABTEILUNG.



**pba S.p.A.** T +39 0424 5451 info@pba.it www.pba.it  
**pba USA, Inc.** T +1 212 255 4605 office@pba-usa.us www.pba.it  
**pba S.p.A. Deutschland** T +49 2151 820060 info@de.pba.it www.pba.it